

Installation & Operation Manual for A1301A, A1301B, A1310A & A1310B Relief Valves

MANUFACTURED BY PARKER PGI

December 2012

Form FVC 001 - Rev 03

IMPORTANT: KEEP THIS DOCUMENT WITH THE PRODUCT UNTIL IT REACHES THE END USER.

WARNING!

1. Contact with or inhalation of Liquid Anhydrous Ammonia (NH₃) or of LP Gas can cause SERIOUS INJURY OR DEATH.
2. Before installation or removal of any tank valve, the system must be purged of all product.
3. Personal Protective Equipment (PPE), safety gloves, goggles and clothing should be worn.
4. For proper handling and storage of NH₃, and Liquefied Petroleum Gas refer to ANSI Standard K61.1 and NFPA Pamphlet 58.
5. An abundant supply of fresh water should be available to provide immediate first aid treatment for exposure to NH₃ and LP-Gas.
6. To prevent the accidental opening of any valve, never grasp or carry a valve by its Hand wheel or handle.
7. To ensure long term safe operation, the manufacturer recommends that under normal service conditions this product should be inspected at least once every year and be repaired or replaced as required.

TOOLS REQUIRED: Safety Equipment (i.e. gloves, goggles, and clothing), 12" Adjustable Wrench, 7/16" Open End Wrench, and 12" Pipe Wrench.

A person should never stand directly over or in front of, or look directly into a relief valve when the tank is pressurized. The relief valve could suddenly "pop" open, blowing gas, dirt and other debris into the person's face and eyes.

To ensure safe operation, the manufacturer recommends that a relief valve not be used for longer than 5 years from the date of installation. Only personnel trained in the proper procedures, codes, standards and regulations should install and/or inspect this equipment. Failure to follow these instructions or to properly install and maintain this equipment could result in property damage and/or personal injury or death.

An abundant supply of clean water must be readily available and easily accessible as a means of providing IMMEDIATE First Aid treatment for exposure to ANHYDROUS AMMONIA.

INTRODUCTION

SCOPE OF THIS MANUAL:

This manual covers instructions for the installation and operation of A1301A, A1301B, A1310A and A1310B relief valves.

NOTES TO THE END USER:

1. The purpose of a relief valve is to keep the tank from rupturing due to excessive tank pressure by venting gas to the atmosphere until the tank pressure drops. Excessive tank pressure can be caused by any of the following:
 - Exposure to fire or radiant heat, including hot summer days
 - New or refilled tanks that have not been fully purged of air
 - Tank colors (other than white) increase the heat absorption of the tank, thus raising the pressure in the tank
 - Overfilling the tank
2. Do not beat, pound or hit the relief valve with hammers or other tools.
3. Do not attempt to force the valve closed, as this will not stop gas discharge and could damage relief valve parts or rupture the tank.
4. Call your dealer if the relief valve discharges gas.

CAUTION: If the valve is to be used for service other than anhydrous ammonia or air, contact the factory to determine if the valve materials are suitable for the particular service.

SPECIFICATIONS

Most states' regulations require that valves are listed by Underwriters' Laboratories, although some states require ASME capacity rated valves. Be sure the valve is rated and stamped to meet the requirements of the state where it will be used. The valve should also have sufficient capacity for the container size where it is used. Required relief valve capacity is a function of the container surface area.

The start-to-discharge pressure stamped on the valve must be correct for the design pressure of the container. Do not use a valve with a start-to-discharge pressure higher than the design pressure of the container.

When a valve has an outlet pipe away stack (such as used in bulk storage applications), a restriction may result that reduces valve capacity below that stamped on the valve. In these cases, the total system capacity must be sufficient to meet the sizing requirements for the container being used.

While this information is presented in good faith and believed to be accurate, Individuals using this literature must exercise their independent judgment in evaluating product selection and determining product appropriateness for their particular purpose, system requirements and certifications. The manufacturer reserves the right to change product designs and specifications without notice.

INSTALLATION

Installed valves must have direct contact with the vapor space of the containers. Install the valve so that flow is unobstructed. Each application will dictate whether discharge stacks or deflectors are required. Deflectors and adapters are separate devices mounted to the outlet of the valve to control discharge direction. Coat the male threads of the valve with a sealing compound listed by Underwriters' Laboratories. Do not allow excess compound to drip into the container or flow around the bottom edge of the pipe threads.

Pull the valve into the coupling hand-tight, then tighten approximately two additional turns with a wrench. Do not install the valve with such extreme torque that the coupling can cut threads into the valve. This could cause valve distortion and affect the internal working parts. Larger size valves may require an additional amount of torque to obtain a leak-free connection.

Raincaps are required on all valves. The raincap should be kept in place. An out-of-place raincap indicates the valve may have opened to relieve overpressure. Most relief valves have a drain hole in the body which must remain open at all times. New containers must be purged to remove air from the container. Failure to properly purge may result in excessive pressure and the possibility of "popping" the relief valve when the container is filled.

REFER TO FIGURE 1:

The relief valve is held closed by the spring force seating the rubber valve disc against the orifice. When the tank pressure exceeds the spring force, the valve disc lifts off the orifice and allows gas to discharge through the valve to the air. Gas discharge initially may be small, producing only seepage and a light "hissing" sound. As pressure increases and gas volume discharge continues, a "popping" condition will occur and large volumes of gas will discharge with a loud "hissing" or "roaring" sound. When the tank pressure decreases enough, the force of the spring will close the disc back against the orifice, stopping further discharge.

MAINTENANCE AND REPLACEMENT

Safety relief valves are non-repairable valves and can not be adjusted in the field.

Any valve that has fully opened or "popped" should be tested to ensure that it is within the allowable start-to-discharge pressure setting. If it is not within the correct range, it must be replaced. Relief valve start-to-discharge and re-seat pressures may be lower if the valve has fully opened (popped).

Some relief valve installations require periodic testing or replacement, such as those required by ANSI K61.1 and/or any applicable local codes. It is recommended that all relief valves be regularly inspected for visible damage, dirt, corrosion, missing raincaps, paint inside outlet, tampering, etc. If any of the preceding is evident or questionable, the valve should be retested or replaced immediately.

The discharge side of the relief valve body must be kept free of dirt, water and other foreign matter which can damage the valve seat or jam the valve disc or poppet. This can prevent the valve from opening. Replace valves when this occurs.

Relief valves are precisely set by the manufacturer for the correct start-to-discharge setting, and field repair should never be attempted. Since the disc in a relief valve is subject to normal deterioration, the manufacturer recommends that a relief valve not be used for longer than 5 years from the date of installation. Earlier replacement may be required due to severe service conditions or code requirements.

LIMITED ONE-YEAR WARRANTY

Squibb-Taylor warrants the product identified herein to be free from defects in material and workmanship under normal use and service. If, within one year from the date the product is shipped from the factory, any unit fails to meet customer satisfaction, it will be replaced free of charge by Squibb-Taylor, FOB Dallas, Texas.

The owner's responsibility is for normal maintenance and any servicer's travel and labor charges.

This warranty applies only when the product is used for consumer use within the United States or Canada and is installed and used in accordance with all applicable national, state and local codes, regulations and laws.

This warranty shall not apply if the product has been subjected to unreasonable use, negligence, accident in transit, alteration, improper installation or misapplication.

Squibb-Taylor shall not be liable for any default or delay in performance under this warranty caused by any contingency beyond its control, including without limitation, war, government restrictions or restraint, strikes, flood or a shortage or reduced supply of raw material.

There are no expressed warranties other than set forth above. All implied warranties, including implied warranties of merchantability and fitness for a particular purpose, are limited to the duration of the expressed warranties set forth above. Liability for consequential damages under this warranty is excluded to the extent exclusion is permitted by law.

This warning gives you certain rights and you may have other rights which vary from state to state.

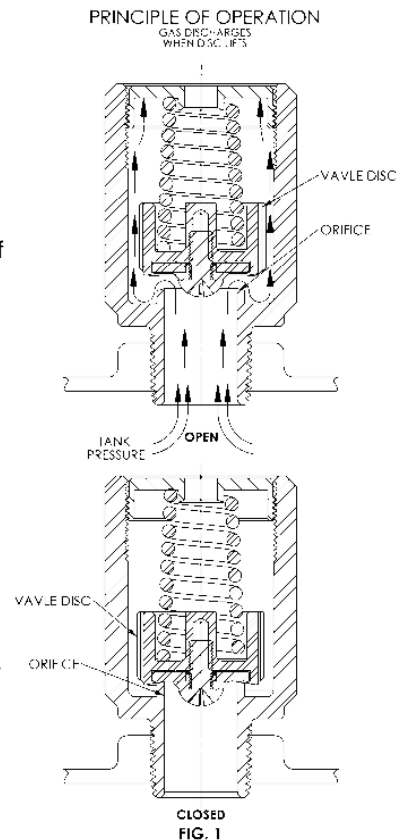

While this information is presented in good faith and believed to be accurate, individuals using this literature must exercise their independent judgment in evaluating product selection and determining product appropriateness for their particular purpose, system requirements and certifications. The manufacturer reserves the right to change product designs and specifications without notice.