

MANUFACTURED BY PARKER - PGI DIVISION

March 2014

Form FVC097 - Rev03

TriPod Safety Coupler Installation & Operating Instructions for Models TP4, TP5, TP6, and TP7

IMPORTANT: KEEP THIS DOCUMENT WITH THE PRODUCT UNTIL IT REACHES THE END USER.

1. Contact with or inhalation of Liquid Anhydrous Ammonia (NH₃) or of LP Gas can cause SERIOUS INJURY OR DEATH.
2. Before installation or removal of any coupler, the system must be purged of all product.
3. Personal Protective Equipment (PPE), safety gloves, goggles and clothing should be worn.
4. For proper handling and storage of NH₃, and Liquefied Petroleum Gas refer to ANSI Standard K61.1 and NFPA Pamphlet 58.
5. An abundant supply of fresh water should be available to provide immediate first aid treatment for exposure to NH₃ and LP-Gas.
6. To ensure long term safe operation, the manufacturer recommends that under normal service conditions this product should be inspected at least once every year and be repaired or replaced as required.

TOOLS REQUIRED: Safety Equipment (i.e. Gloves, Goggles, and Clothing), 12" Adjustable Wrench, Adjustable Wrench, Allen Wrench, Torque Wrench, and Pipe Wrench(2).

PRINCIPLES OF OPERATION

The Tri Pod Safety Coupler is designed to provide pull away protection between the vapor hose and the bulkhead. It's non-destructive releasing mechanism will operate reliably with a pull away force in any generally horizontal direction. In addition, the torque needed to release the liquid and vapor Tri Pods is only 500 Ft.Lbs total, therefore the bulkhead does not normally require additional structural bracing. So in most cases, the Tri Pod can quickly be installed in existing bulkhead applications.

All SS construction ensure long trouble free operating life.

OPERATION INSTRUCTIONS

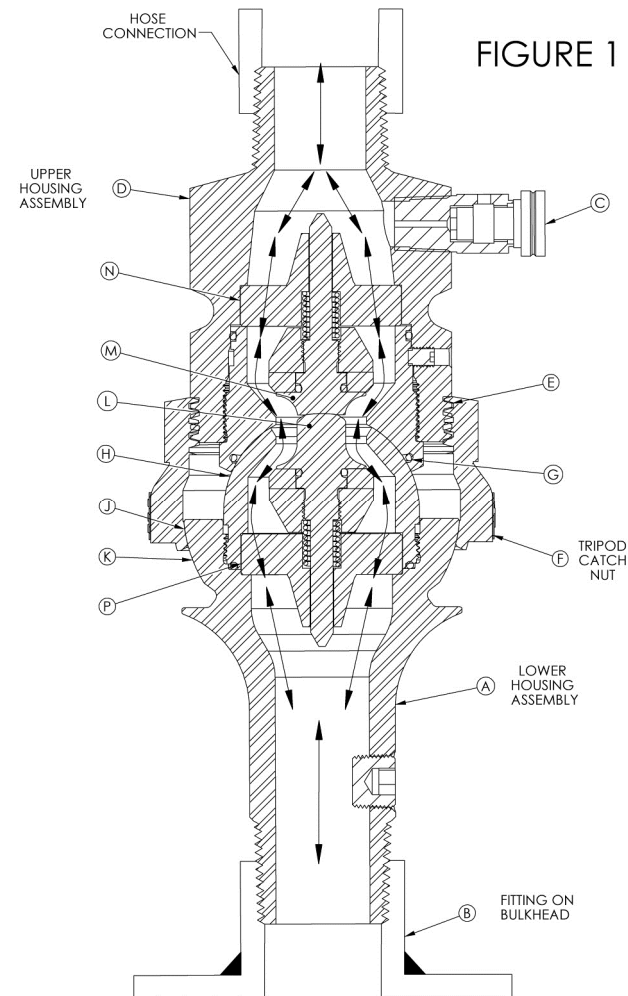

FIGURE 1

The Tri Pod is typically installed on the bulkhead between the storage tank and the transport or bobtail. **Figure 1** shows a TP1 Tri Pod in cross section. The Tri Pod Lower Housing Assembly (A) is tightened into the Bulkhead Fitting (B). The Tri Pod must be installed in the vertical position for a horizontal pull to release the coupling. The Upper Housing Assembly (D), has an Integral Bleeder (C), which is used to vent trapped liquid after a pull away. The Upper Housing (D), is threaded into the hose connection. The Upper Housing Assembly (D) is threaded at (E) to receive the catch nut (F), which when tightened traps the Tripod Upper and Lower Housing Assemblies (A) and (D), into sealing engagement.

The Upper Housing (D) to Lower Housing (A) assembly seal is made by a O-Ring (G) which is located on the hardened stainless steel Ball Socket Joint (H). The female half is part of the Upper Housing Assembly (D), and the male half is part of the Lower Housing Assembly (A).

As the catch nut is tightened, it "catches" or contacts the outer tip of each of the three Tri Pod Legs (J), which pulls the Tri Pod Lower Housing (A), into contact with the Upper Housing (D). The extent to which the catch nut is tightened will largely determine the force required, in the horizontal direction, to disengage the coupling.

The outer surface of the Tri Pod Lower Housing Legs (K), and the inner surface of the Catch Nut (F) also defines a ball socket that is larger than the inner sealing ball socket. The center point of the ball sockets are identical which allows the Tri Pod Lower Housing (A) to rotate without jamming until disengaged from the catch nut.

While this information is presented in good faith and believed to be accurate, Individuals using this literature must exercise their independent judgment in evaluating product selection and determining product appropriateness for their particular purpose, system requirements and certifications. The manufacturer reserves the right to change product designs and specifications without notice.

OPERATION INSTRUCTIONS Cont.

The center section of the Tri Pod contains two spring loaded back checks L and M. They hold each other open in normal operation and are suspended in the flow stream by back check support members N and P which have thin legs to support the back check valves yet allow flow to occur around the stem supports.

The mechanical operation of the Tri Pod during release is shown in Figure 2. A release is initiated when a horizontal force at point A (Due to pull away) over comes the frictional forces at both the inner and outer ball sockets B and C respectively. The amount of frictional force present was determined by the tightness of the Catch Nut ⑤.

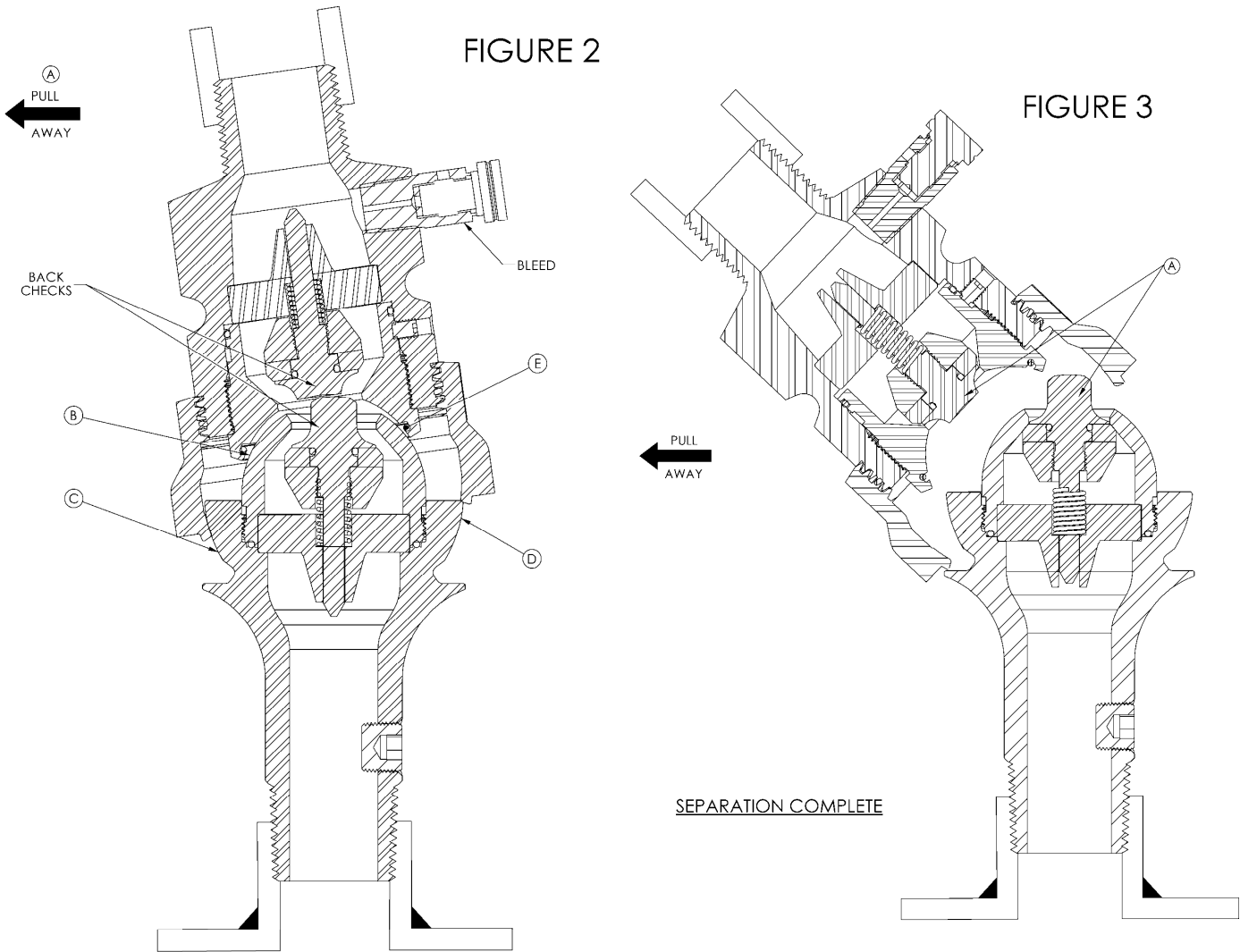

As the Tri Pod Upper Housing pivots, the catch nut will rotate out of contact with one or two of the three Tri Pod legs ④. While rotation is occurring the O-Ring ⑤ on the Inner Ball Socket ⑥ maintains the product seal until release occurs. After a maximum rotation of 25 degrees, the Tri Pod Upper Housing ④ and Catch Nut Assembly ⑤ will separate from the Lower Housing Assembly ①.

After release occurs the two all stainless steel spring assisted Back Check Valves ①, will close very quickly to minimize product release as shown in Figure 3. The Back Check's ① Viton/Teflon seat, provides a pressure tight seal. The Tri Pod Upper Housing ④ and Catch Nut ⑤ with the Back Check ① closed, remains attached to the vapor hose and follows the pull away vehicle until stopped. After proper bleed down of the system as described under the "Operating Instructions", the Upper Housing ④ and hose can quickly be reconnected to the Lower Housing Assembly ① returning the fill station to operation.

While this information is presented in good faith and believed to be accurate, Individuals using this literature must exercise their independent judgment in evaluating product selection and determining product appropriateness for their particular purpose, system requirements and certifications. The manufacturer reserves the right to change product designs and specifications without notice.

INSTALLATION INSTRUCTIONS

Bulkhead Requirements:

Before starting installation, close the liquid and vapor ESV or main shut off valves between the Bulk Head and storage tank and vent all lines.

The Bulk Head, (see Figure 4), must be equipped with a vertical connection for installing the liquid and vapor Tri Pods. The connections should be a minimum of 10 inches apart. These connections must be secured to the Bulk Head, and able to withstand a minimum pull-away torque of 500 Ft.lbs. This would be an equivalent of a 500 lbs. horizontal load on the TP1 fitting at the bulkhead connection (A) in Figure 4.

NOTE: It is recommended that a 45 degree Tri Pod to hose adapter is used for both liquid and vapor Tri Pods as seen in Figure 4. This will reduce the chances of the Housing becoming entangled with obstacles during a pull away.

CAUTION: The Transport or Bobtail piping must be strong enough to support Tri Pod pull away torque of 500 Ft.Lbs.

CAUTION: Check that the area is free and clear of obstacles that hoses could hang on during a pull away from any direction

Tri Pods currently come in four models for use in bulk head applications.
(Refer to liquid propane bulk head IO&M manual when installing a TP4)

Model	Flow Capacity	Application	Separation Torque Bulkhead/Transport
TP4	300 GPM of LP at 10 PSI Differential	Liquid Line	350 Ft.lbs
TP5		Vapor Line	100 Ft.lbs
TP6		Vapor Line	200 Ft.lbs
TP7		Vapor Line	200 Ft.lbs

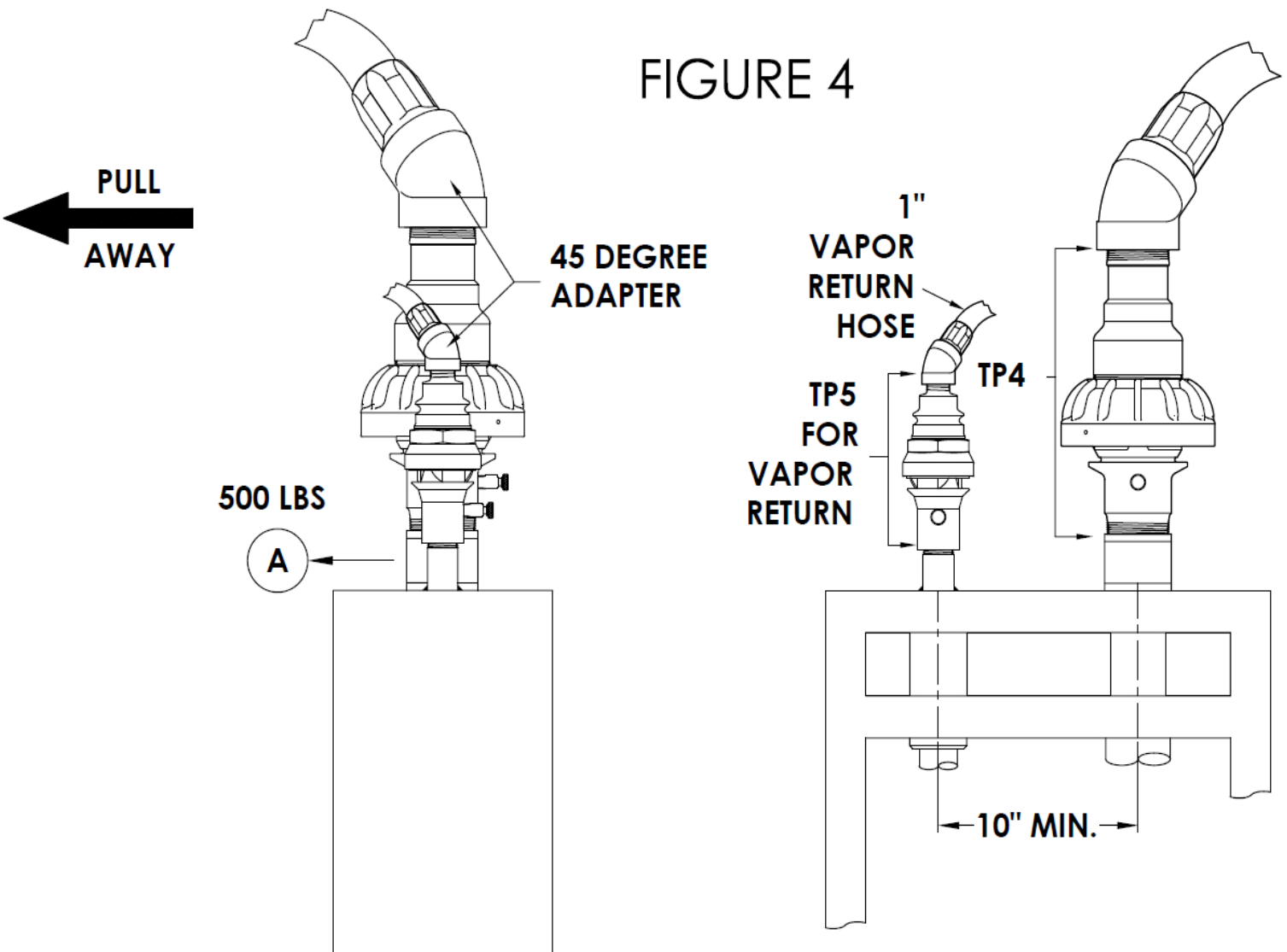

While this information is presented in good faith and believed to be accurate, Individuals using this literature must exercise their independent judgment in evaluating product selection and determining product appropriateness for their particular purpose, system requirements and certifications. The manufacturer reserves the right to change product designs and specifications without notice.

INITIAL INSTALLATION

Properly installed bulk head piping must have an excess flow valve installed to protect the liquid and vapor lines. The flow capacity of a Tri Pod installed to protect a line must exceed the rating of the excess flow valve protecting that line.

1. Screw the lower housing assembly into the bulk head. If possible position the Bleed Valve Port in the opposite direction of the disconnect (see Figure 2.) Tighten at location ① in Figure 5 with a pipe wrench, taking care not to damage the Bleed Valve's 1/4" NPT threads.

CAUTION: The Lower Housing ① must be attached to the bulk head. The Tri Pod will not operate properly if the Upper Housing ② is attached to the bulk head.

2. Attach the hose or coupling to the Upper Housing ②.

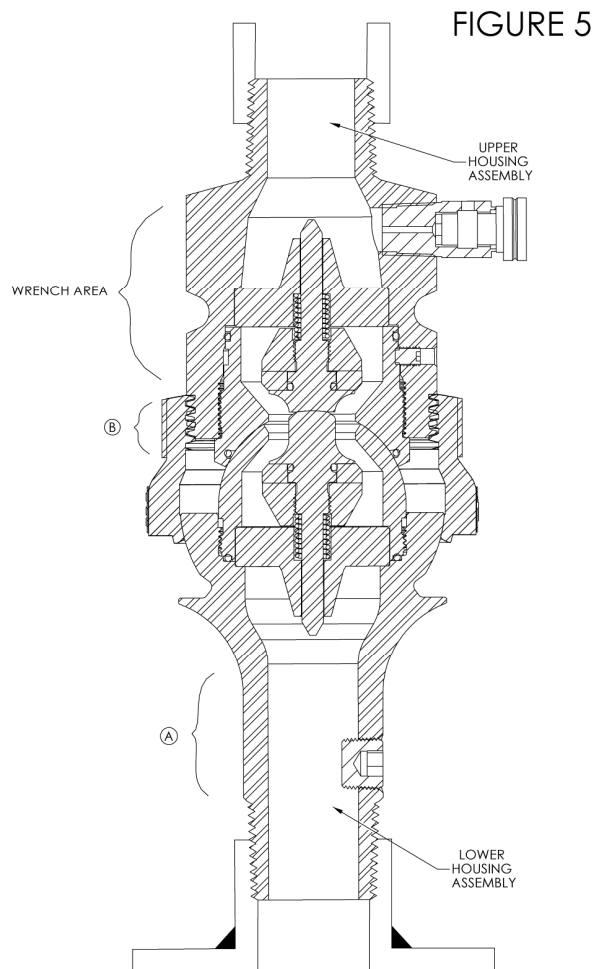

3. Screw the catch nut down (off) until the internal threads are slightly exposed. (see B in Figure 6).

NOTE: The Catch Nut is screwed down to this position so the back checks will not interfere with each other when the Upper Housing ② is placed on the Lower Housing ①.

CAUTION: Check that the hoses connected to the Tri Pod will pull free in the event of a pull-away in all possible directions.

4. Set the Catch Nut and Upper Housing ② over the Lower Housing ① Legs. While holding the Upper Housing ② in position, tighten the Catch Nut firmly by hand.

NOTE: Be sure to hold the Upper Housing ② in a vertical position while tightening the Catch Nut or the Lower Housing ① will disengage.

5. Tighten the Catch Nut 1/8" turn with a pipe wrench ③ on its wrench area as shown in Figure 5.

CAUTION: Do not over tighten the Catch Nut. It must be tight enough to not disengage with normal hose handling but should not be tightened past that point.

6. Grab the hose fitting by hand and try to move the Tri Pod Upper Housing ②. If it can be moved by hand, tighten the Catch Nut 1/16 turn or less and try again.

NOTE: Striking the hose fitting with the heel of your hand to see if it will move, is also a technique that can be used.

While this information is presented in good faith and believed to be accurate, Individuals using this literature must exercise their independent judgment in evaluating product selection and determining product appropriateness for their particular purpose, system requirements and certifications. The manufacturer reserves the right to change product designs and specifications without notice.

NOTE: If you are unsure about the tightness simply test what you have done by whipping the hose around to simulate handling and then pull on the hose to test the ease of disconnect. Reconnect, tighten and do a manual pull-away as many times as needed. No harm is done by operating the Tri Pod.

7. Make sure the Tri Pod Upper Housing ① is straight to the eye with the Lower Housing ②. If not, loosen the Catch Nut by turning it counter clock wise. Tap it straight and retighten the Catch Nut to its previous point.

NOTE: If the Lower and Upper Housing A and D are not aligned properly there will be a flow restriction across the ball socket orifices.

8. Using Teflon tape or pipe sealant install the Bleed Valve into the Lower Housing ③. Close the Bleed Valve.
9. Connect the liquid side of the bulk head application by using the IO&M manual included with the Tripod used in liquid installations.

RECONNECTION AFTER PULL AWAY

1. Close the liquid and vapor ESV or main shut off valves between the bulk head and storage tank.
2. Close the hose end valves on both the liquid and vapor lines which are still attached to the transport or bobtail.

CAUTION: Both the liquid and vapor lines are full of product which must be safely bled off.

3. Take the liquid and vapor hose assembly to a water tank (for trapped anhydrous ammonia) and bleed off the trapped product by opening the hose end valves slowly where the valve is held at least 12 inches under water.
4. Bleed down the product trapped between the ESV or main shut off valve and Tri Pod Lower Housing ④ by slowly opening the bleeder on the Tri Pod.

CAUTION: Leave bleeders and hose end valves open until after the Tri Pod reconnection, otherwise pressure will build up in the cavity and discharge product when the back checks are opened during reconnection.

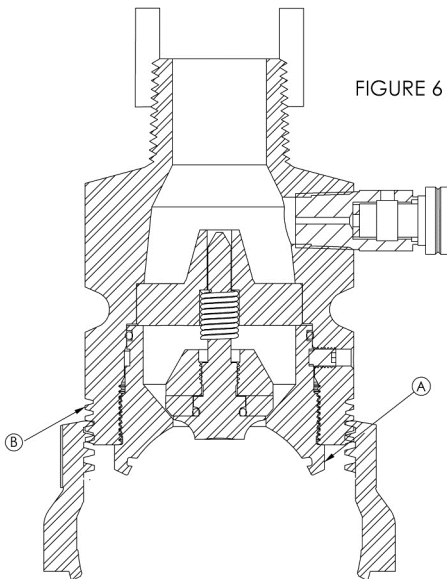

FIGURE 6

5. Inspect the bulk head, hose end valves, and hose, for signs of damage or cracking.
6. Inspect for the presence of the sealing O-Rings ⑤ in FIGURE 6. If they are missing or cut, replace them.

NOTE: On a disconnect, it is not unusual for the sealing O-Ring to blow out of the ring groove and lodge at the base of the male ball lower housing.

7. Complete steps 3-7 in the Initial Installation Section of this manual.

USER SAFETY RESPONSIBILITY STATEMENT FOR ALL PARKER PRODUCTS

FAILURE OR IMPROPER SELECTION OR IMPROPER USE OF THE PRODUCTS DESCRIBED HEREIN OR RELATED ITEMS CAN CAUSE DEATH, PERSONAL INJURY AND PROPERTY DAMAGE.

- This document and other information from Parker-Hannifin Corporation, its subsidiaries and authorized distributors provide product or system options for further investigation by users having technical expertise.
- The user, through its own analysis and testing, is solely responsible for making the final selection of the system and components and assuring that all performance, endurance, maintenance, safety and warning requirements of the application are met. The user must analyze all aspects of the application, follow applicable industry standards, and follow the information concerning the product in the current product catalog and in any other materials provided from Parker or its subsidiaries or authorized distributors.

To the extent that Parker or its subsidiaries or authorized distributors provide component or system options based upon data or specifications provided by the user, the user is responsible for determining that such data and specifications are suitable and sufficient for all applications and reasonably foreseeable uses of the components or systems.

While this information is presented in good faith and believed to be accurate, Individuals using this literature must exercise their independent judgment in evaluating product selection and determining product appropriateness for their particular purpose, system requirements and certifications. The manufacturer reserves the right to change product designs and specifications without notice.