

(214) 357-4591 DALLAS TEXAS (800) 345-8105

MANUFACTURED BY PGI INTERNATIONAL

Installation, Operation, Maintenance Disassembly and Assembly Instructions for Model A522P & A522R Liquid Fill and Withdrawal Valve

October 2012

Form FVC 092 - Rev 02

IMPORTANT: KEEP THIS DOCUMENT WITH THE PRODUCT UNTIL IT REACHES THE END USER.

WARNING!

1. Contact with or inhalation of liquid Anhydrous Ammonia (NH₃) or NH₃ vapor can cause SERIOUS INJURY OR DEATH.
2. Before installation or removal of any tank valve, the system must be purged of all product and Personal Protective Equipment (PPE), safety gloves, goggles and clothing should be worn.
3. For proper handling of NH₃, refer to ANSI Standard K61.1
4. An abundant supply of fresh water should be available to provide immediate first aid treatment for exposure to NH₃.
5. The valve Seat should be inspected for cracking in NH₃ service at least once every 2 years and replaced as required.
6. **Closure of the excess flow check in the valve will not totally stop the flow of NH₃ since the check disk has a small opening in it to allow the check disk to automatically reset.**
7. **The Excess flow safety device used in this product will close ONLY if the rated flow rate is achieved through the valve.**
8. **Downstream restrictions, partial breaks and/or low tank pressure can result in failure to achieve the excess flow rate and the excess flow check WILL NOT CLOSE.**
9. **Connecting two withdrawal valves to one tank will reduce the flow through each valve by approximately 50% thereby affecting the ability of the excess flow valves to close with multiple hose failures. Also, piping should not allow one withdrawal valve to "backfeed" the other. Appropriately located back checks must be installed.**
10. **The operation of the excess flow device should be tested before every season.**

INSTALLATION / REMOVAL

WARNING!

1. To prevent unexpected pressure buildup in the system, always keep the Valve Handle in the OPEN POSITION during installation or removal.
2. Before installation or after removal, check the Excess Flow Disk for free operation between FULLY CLOSED & FULLY OPEN.
3. Make sure the Excess Flow Stem is not bent. Replace the Valve if it is bent.
4. Inspect the Valve Seat for hardening or cracking and replace if either is observed.

OPERATION

1. Open the Valve slowly to avoid the Excess Flow Check from closing. If it does, you will hear a "click" and flow will be slowed to a very small amount.
2. If the Excess Flow Disk is tripped, close the Valve. This will allow the Excess Flow Check to reset automatically, then you may try again to open the valve slowly.

TESTING THE EXCESS FLOW SHUT-OFF

1. Connect a test hose to the nurse tank. The test hose should be the same length and size as the normal hose used in the field and have a ball valve at the far end, followed by a bleeding system that can be submerged in water without restricting FULL OPEN flow.
NOTE: This test should be conducted at tank pressures representative of the lowest application tank pressure.
2. Close the ball valve, open the withdrawal valve, submerge the bleed system at least 12 inches deep in the water, crack open ball valve for 10 seconds to fill hose with liquid, shut ball valve, then quickly open the ball valve FULL OPEN.
3. After a brief burst of flow, the Excess Flow Device should close, then the flow should be reduced to a small amount. After flow has reduced close the withdrawal valve then the test hose may be bled down safely and removed from the withdrawal valve.

WARNING! If the excess flow did not close, then use a valve with a LOWER excess flow rate.

DISASSEMBLY PROCEDURE FOR REPAIR

- Step 1:** With valve secured in a bench vise, remove Bonnet ⑤ from the Body ⑱, which will expose the complete Bonnet and Stem Assembly.
Note: It is important to inspect Disc Holder ② rotation. If it does not rotate freely, do not use valve but consult your local dealer for instructions. Remove old Gasket ⑱.
- Step 2:** Secure Bonnet ⑤ in a bench vise and remove both Handwheel and Disc Nuts ①. Remove Disc Washer ①, Disc ⑩, Handwheel ②, and Info-Disc ⑫. Remove Packing Nut ④, Chevron Packing ⑭, Male Adapter ⑮, and Packing Spring ⑰ over the end of Stem ③.
- Step 3:** Rotate Stem ③ clockwise (CW) using Handwheel ② if necessary, until stem is disengaged from Bonnet ⑤. Remove old Gasket ⑱. Before reassembly, clean and inspect the valve seat at ⑥. Clean all metal components with solvent and wipe or blow dry with air.

While this information is presented in good faith and believed to be accurate, Individuals using this literature must exercise their independent judgment in evaluating product selection and determining product appropriateness for their particular purpose, system requirements and certifications. The manufacturer reserves the right to change product designs and specifications without notice.

TO REPAIR OR REPLACE BONNET

- Step 1:** Install Disc ⑩, Disc Washer ⑪, and Disc Nut ① to Disc Holder ⑨. Secure Disc Nut ① to threads of Disc Holder ⑨ with center punch mark at thread interface.
- Step 2:** Lubricate threads of stem with a good quality grease and install Stem ③ into Bonnet ⑤ until Disc Holder ⑨ rests against bottom of bonnet.
- Step 3:** With the bonnet and stem assembly secured in a bench vise install Gasket ⑬ and Packing Spring ⑰.
- Step 4:** Replace O-ring ⑬ in groove of Packing Nut ④. Install Chevron Packing ⑭ and Male Adapter ⑮ into Packing Nut ④.
- Step 5:** Lubricate exposed surface of Stem ③ with John Crane Style 279A Packing Lubricant or equal.
- Step 6:** Place Packing Nut ④ with packing in place over Stem ③ and engage bonnet threads in Bonnet ⑤. Rotate Packing Nut ④ while making contact with bonnet threads. Tighten packing nut with torque wrench to 55 ft.-lbs.
- Step 7:** Secure Body ⑱ in vise. Place Body Gasket ⑲ over bonnet threads and lubricate threads with a good quality grease.
Note: Install bonnet assembly into body and tighten with torque wrench to 95 ft.-lbs. Install Info disc ⑫.
- Step 8:** Install Handwheel ②, and tighten Handwheel Nut ① on Stem ③.
- Step 9:** Check stem packing and valve seat for leaks. Operate handwheel full open to full closed to insure smooth operation.

UPPER ASSEMBLY REMOVAL AND REPAIR

- Step 1:** With valve secured in bench vise, remove the Upper Assembly ⑳ from Body ⑱, remove old Gasket ⑳.
- Step 2:** Secure Upper Assembly in a bench vise and remove Hex Nut ㉔, Seal carrier ㉕, Seal ㉖, O-Ring ㉗, Spring ㉘, Washer ㉙ and Stem ㉚.

REPAIR INSTRUCTIONS FOR UPPER ASSEMBLY

- Step 1:** Slide Spring ㉘ on to the Stem ㉚ and insert into Body ㉙. Slip Washer ㉙ and O-ring ㉗ over end of Stem ㉚.
- Step 2:** Place Seal ㉖ on Seal Carrier ㉕ and then slip the seal assembly over the threaded end of the Stem ㉚ with rubber Seal ㉖ facing inward toward the body.
- Step 3:** Next fasten Seal ㉖ onto Stem ㉚ with Hex Nut ㉔, then stake nut with a center punch.
- CAUTION:** All parts included in this kit should be used. Check for free movement of back check assembly by pushing in on head of Stem ㉚ and releasing.
- Step 4:** Secure body in vise, place the Gasket ㉙ over the upper assembly threads and lubricate threads with a quality grease.
- Step 5:** Install upper assembly into body and tighten with torque wrench to 95 ft.-Lbs.

INSPECTION AND / OR REPLACEMENT OF THE EXCESS FLOW ASSEMBLY

- Step 1:** Excess Flow Valves are a Safety Device which will Close in the event of a hose failure i.e., a pull away or accident which causes the hose to be Severed Completely. It is of utmost importance that these valves be Installed and Operated Properly in order to provide the Safety Protection they were designed to give.
- a.) **TO INSPECT:** Place the palm of the hand against the hex head of Check Stem ㉛ and depress Spring ㉘ until Poppet Check ㉛ is at full stroke against the Yoke Seat ㉜. Release the Check Stem ㉛, and observe the spring return stroke. If the excess flow assembly does not move freely toward Yoke Seat ㉜ or exhibit a snap action on the spring return stroke, it must be replaced.
Note: The complete excess flow valve assembly number is S1597-1145.
- b.) **TO REMOVE:** Secure the valve body in a bench vise and using a pipe wrench rotate the Excess Flow Assembly ㉟ counter clockwise (CCW) to remove from Valve Body ㉙.
- c.) **TO REPLACE:** Clean the internal body threads with a wire brush or solvent and wipe or blow dry with air. Apply the loctite thread adhesive, part # TL 29005 provided with the Excess Flow Assembly kit to the Yoke ㉟ and body threads. Install the new Excess Flow Assembly into the body and tighten with the pipe wrench.
- CAUTION:** Do not allow loctite to contact the stem or check disc. Allow 30 minutes to dry and check operation of assembly per a.) above.
- Step 2:** Before reassembly, clean and inspect the valve seat at ㉜. Clean all metal components with solvent and wipe or blow dry with air.

INSTALLATION OF NEW OR REPAIRED TANK VALVES

- CAUTION:** Older valves which incorporate an open yoke style excess flow must not be installed in tanks without the use of a proper sized dip tube.
REFER TO FIGURE 1 FOR THE FOLLOWING STEPS:
- Step 1:** Holding the valve in hand, depress and release Check Stem ㉛ to insure that it is operating smoothly.
- Step 2:** Apply Teflon tape or sealant on 1-1/4" NPT Threads, and place handwheel in full open position.
- Step 3:** Install valve into threaded tank fitting and tighten to desired position, taking caution to not over tighten.
- CAUTION:** Do not damage Check Stem ㉛ while installing valve.

While this information is presented in good faith and believed to be accurate, Individuals using this literature must exercise their independent judgment in evaluating product selection and determining product appropriateness for their particular purpose, system requirements and certifications. The manufacturer reserves the right to change product designs and specifications without notice.

NO.	DESCRIPTION	QTY.
1	HAND WHEEL NUT / DISC NUT	2
2	HAND WHEEL	1
3	STEM	1
4	PACKING NUT	1
5	BONNET	1
6	LOCTITE PACKAGE N/S	1
7	YOKE	1
8	BALL	15
9	DISC HOLDER	1
10	DISC	1
11	DISC WASHER	1
12	INFORMATION DISC	1
13	O-RING	1
14	CHEVRON PACKING	2
15	MALE ADAPTER	1
16	GASKET	1
17	PACKING SPRING	1
18	BODY GASKET	1
19	BODY	1
20	RETAINING SCREW	1
21	1/4" NPT HEX HD. PLUG	1
22	POPPET CHECK	1
23	STEM CHECK	1
24	SPRING	1
25	GUIDE CHECK	1
26	GASKET	1
27	ACME CAP	1
28	SPRING	1
29	UPPER BODY	1
30	GASKET	1
31	STEM	1
32	WASHER	1
33	SEAL	1
34	SEAL CARRIER	1
35	O-RING	1
36	HEX NUT	1
37	WARNING LABEL	1

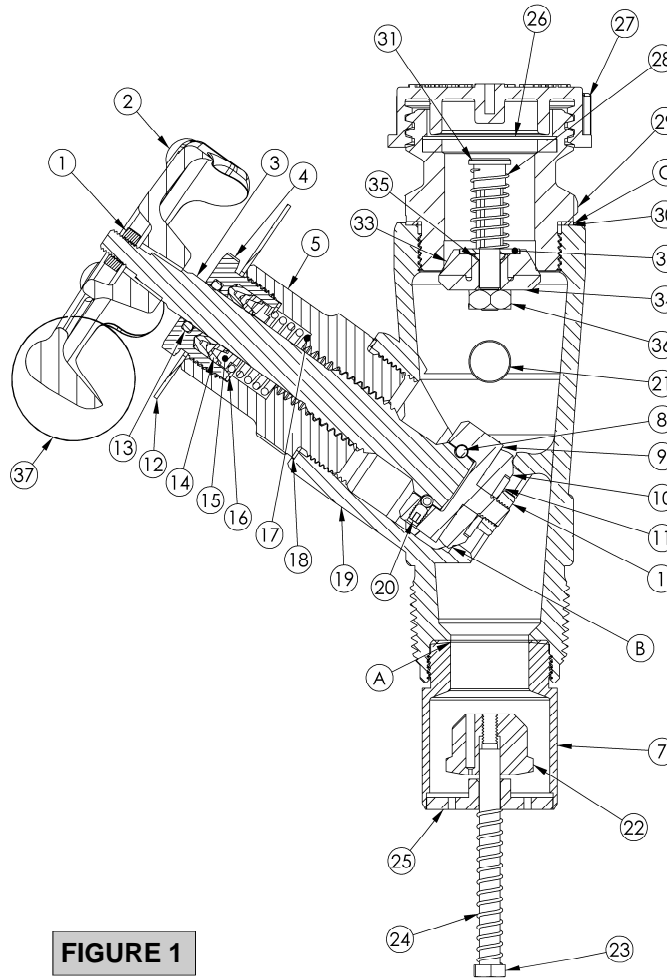

FIGURE 1

AVAILABLE KITS		
NUMBER	NAME & PARTS INCLUDED	ASSEMBLY PROCEDURE
310-0022	SEAL KIT ① ⑩ ⑬ ⑭ ⑮ ⑯	STEPS 1 THRU 11
310-1300	STEM & DISC HOLDER ASSEMBLY ① ③ ⑧ ⑨ ⑩ ⑪ ⑳	STEPS 2 THRU 11
310-1100	BONNET ASSEMBLY ① ③ ④ ⑤ ⑧ ⑨ ⑩ ⑪ ⑬ ⑭ ⑮ ⑯ ⑰ ⑳	STEPS 8 THRU 11
S1597-1145	EXCESS FLOW ASSEMBLY ⑥ ⑦ ⑳ ㉑ ㉒	SEE DIRECTIONS FOR EXCESS FLOW REPLACEMENT
1105-002	SEAL KIT ㉓ ㉔ ㉕ ㉖ ㉗ ㉘ ㉙	SEE DIRECTIONS FOR UPPER BODY ASSEMBLY REPAIR
1105-1125	UPPER ASSEMBLY ㉚ ㉛ ㉜ ㉝ ㉞ ㉟ ㊱ ㊲ ㊳ ㊴ ㊵	SEE DIRECTIONS FOR UPPER BODY ASSEMBLY REPAIR STEPS 4 THRU 6

While this information is presented in good faith and believed to be accurate, Individuals using this literature must exercise their independent judgment in evaluating product selection and determining product appropriateness for their particular purpose, system requirements and certifications. The manufacturer reserves the right to change product designs and specifications without notice.