



Installation, Operation, Maintenance Disassembly and Assembly Instructions for Models AL414 and AL415

June 2000

Form FVC 032

KEEP THIS DOCUMENT WITH THE PRODUCT UNTIL IT REACHES THE END USER.

WARNING

Before installation or removal of Quick Acting Valves, the system must be purged completely of all product. Use proper safety equipment at all times. An abundant supply of clean water must be readily available and easily accessible as a means of providing IMMEDIATE First Aid treatment for exposure to ANHYDROUS AMMONIA. For LP-Gas service follow NFPA / ANSI 58 Standard for the Storage and Handling of Liquefied Petroleum Gases, plus all Local and State Safety Regulations. To insure long term safe operation, the manufacturer recommends that under normal service conditions this product should be inspected at least once every five (5) years and be repaired or replaced as required.

CAUTION: Contact with or inhalation of Liquid Anhydrous Ammonia or L-P Gas or their vapors can cause serious injury or death. Dispersment must be in accordance with local regulations.
For the proper handling and storage of Anhydrous Ammonia refer to ANSI Standard K61.1.
For the proper handling and storage of Liquefied Petroleum Gas refer to NFPA Pamphlet 58.

TOOLS REQUIRED: Safety Equipment (i.e. gloves, goggles, and clothing), 12" Adjustable Wrench, a 3/16" diameter Drift Pin, a small Ball Peen Hammer, and a 7/16" Open End or Boxed End Wrench

Removal of Valve for Repair or Replacement

REFER TO FIGURE 1 FOR THE FOLLOWING STEPS:

- Step 1: Safety Equipment (i.e. goggles, gloves and clothing) must be worn before continuing with the next step.
- Step 2: Before removing valve, place in FULL OPEN POSITION to insure all pressure is bled from the system.
NOTE: See Warning at top of page.

Disassembly Procedure for Repair

REFER TO FIGURE 1 FOR THE FOLLOWING STEPS:

- Step 1: With valve secured in a bench vise, remove the 3/16" diameter Roll Pin (3), which allows the Handle Assembly (1) to be removed from the Stem (2).
- Step 2: Remove Bonnet (5) from Body (12).
NOTE: The Bonnet will move upward approximately 1/16" after the last thread is disengaged from the Body, allowing the Seat Spring (11) and the Assist Spring (17) to relax to its maximum length. Remove the entire Bonnet Assembly from the Body (12).
- Step 3: With the Bonnet Assembly in hand, remove the Stem Assembly (2) and Springs (11) and (17) from the Bonnet (5).
- Step 4: Remove the Swivel Pad (4) and O-ring (6) from the top of the Bonnet (5). To remove the Seal Retainer (7), O-ring (8), and Seal Washer (9) from the Bonnet (5) place the 3/16 diameter Drift Pin thru the top hole of the Bonnet (5), and gently push against the top shoulder of the Seal Retainer (7).
NOTE: Take care not to let the Drift Pin scratch the Bonnet / O-ring sealing surface as the seal is removed.
- Step 5: To remove Disc Holder (13), insert the 3/16 Drift Pin into the Roll Pin hole at (3) of Stem (2) for support. Remove Hex Jam Nut (16), Disc Retainer (15) and Disc (14). Take care not to damage or mar surface of stem. Discard old Disc (14).

Assembly Procedure

REFER TO FIGURE 2 FOR THE FOLLOWING STEPS:

- Step 1: Install O-ring (8) on the Seal Retainer (7). Lubricate Stem (2) with a good quality grease compatible with the service conditions. From the threaded end of Stem (2), slide this assembly onto Stem (2) with the shoulder side of Seal Retainer (7) facing toward the top of the Stem. See Figure 2 Seal Detail.
CAUTION: Slide the O-ring and Seal Retainer to a position just below the Roll Pin Hole at the top of Stem (2). Do not allow the O-ring and Seal Retainer to engage the Roll Pin Hole.
- Step 2: Install Seal Washer (9) onto Stem (2) with the shoulder side of Seal Washer (9) facing toward the threaded end of Stem (2).
- Step 3: Install Seat Spring (11), Assist Spring (17), Disc Holder (13), Disc (14), Disc Holder Retainer (15), and Hex Jam Nut (16) onto Stem (2). Insert 3/16 Drift Pin into hole of Stem (2), and tighten Hex Jam Nut (16) snug.
NOTE: Hex Jam Nut must be "staked" to Stem thread to insure Nut does not unscrew during operation. See Figure 3.

(OVER)

Assembly Procedure

- Step 4: Lubricate O-ring (8) and the sealing bore of Bonnet (5) with a good quality grease compatible with the service conditions.
- Step 5: Install the complete Assembly of Figure 2 into Bonnet (5), rotating the Assembly as the O-ring (8) and the Seal Retainer (7) enter the sealing bore of the Bonnet.
- Step 6: Install O-ring (6) and Swivel Pad (4) over Stem (2) on top of Bonnet (5).
- Step 7: Place Handle Assembly (1) onto Stem (2), and Install Roll Pin (3).
- Step 8: Replace Bonnet Gasket (10) in top of Body (12). Install the Bonnet Assembly into Valve Body, and tighten hard against the metal Bonnet Gasket (10).
- Step 9: Open and Close Valve several times, then pressure test Valve for leaks at the Stem and Disc locations before returning valve to service.

Installation of New or Repaired Quick Acting

- Step 1: Apply Teflon tape or sealant on male pipe threads of mating part, and place Valve in Open position.
- Step 2: Install Valve and tighten to desired position taking care to not overtighten.

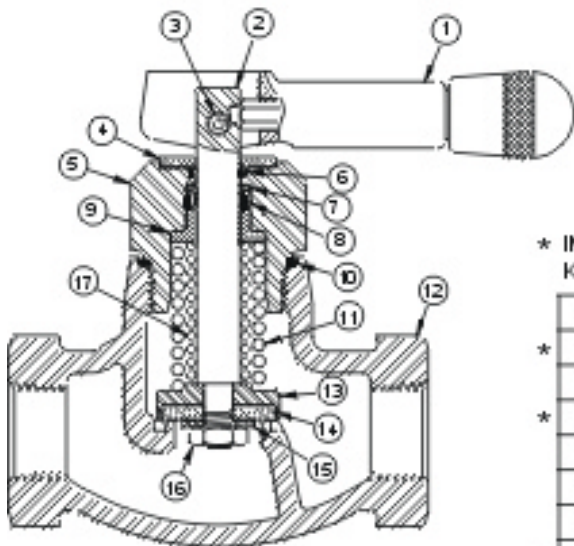

FIG. 1

* INCLUDED IN SEAL
KIT # 415-0022

17	Assist Spring	1
* 16	Hex Jam Nut	1
15	Disc Retainer	1
* 14	Disc	1
13	Disc Holder	1
12	Body	1
11	Seat Spring	1
* 10	Bonnet Gasket	1
* 9	Seal Washer	1
* 8	O-Ring	1
* 7	Seal Retainer	1
* 6	O-Ring	1
5	Bonnet	1
4	Swivel Pad	1
3	Roll pin	1
2	Stem	1
1	Handle Assembly	1
ITEM	DESCRIPTION	QTY

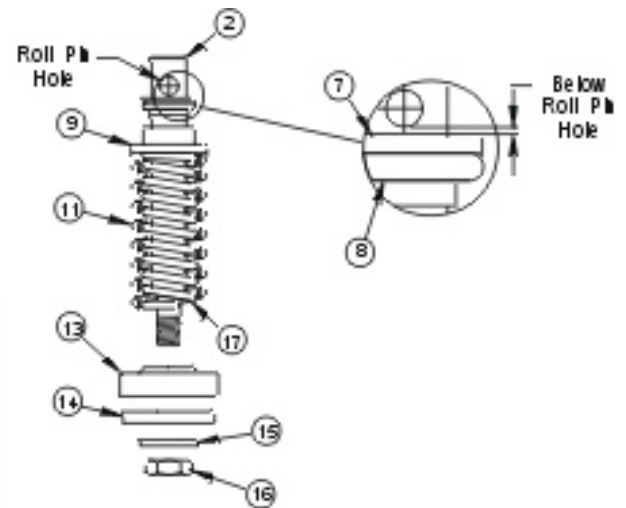

FIG. 2

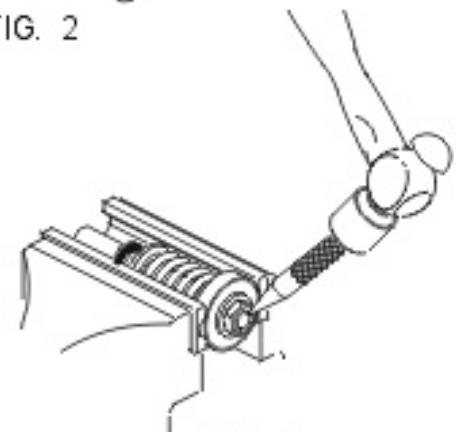

FIG. 3