



Installation, Operation, Maintenance Disassembly and Assembly Instructions for Models AL320FP, AL321FP Globe and Angle Valves

June 2000

Form FVC 029 - Rev. 1

KEEP THIS DOCUMENT WITH THE PRODUCT UNTIL IT REACHES THE END USER.

WARNING

Before installation or removal of any globe or angle valves, the system must be purged completely of all product. Use proper safety equipment at all times. An abundant supply of clean water must be readily available and easily accessible as a means of providing IMMEDIATE First Aid treatment for exposure to ammonia. To insure long term safe operation, the manufacturer recommends that under normal service conditions this product should be inspected at least once every five (5) years and be repaired or replaced as required. To prevent the accidental opening of any valve, never carry or grasp a valve by its handwheel or handle.

CAUTION: Contact with or inhalation of Liquid Anhydrous Ammonia or L-P Gas or their vapors can cause serious injury or death. Dispersment must be in accordance with local regulations.
For the proper handling and storage of Anhydrous Ammonia refer to ANSI Standard K61.1.
For the proper handling and storage of Liquefied Petroleum Gas refer to NFPA Pamphlet 58.

TOOLS REQUIRED: Safety Equipment (i.e. gloves, goggles, and clothing), 12" Adjustable Wrench & 24" Pipe Wrench

Removal of any Globe or Angle Valve for Repair or Replacement

REFER TO FIGURE 1 FOR THE FOLLOWING STEPS:

- Step 1: Safety equipment (i.e. gloves, goggles and clothing) must be worn before continuing with the next step.
- Step 2: Before removing valve from tank, place in **FULL OPEN POSITION** to insure all pressure is bled from system.
Note: See Warning at top of page.
Note: Flanged valves may be repaired while in line, providing system has been completely purged of product.

Disassembly Procedure For Repair

REFER TO FIGURE 1 FOR THE FOLLOWING STEPS:

- Step 1: With valve secured in a bench vise, remove the four Hex Bolts (19). Remove the complete bonnet (5) and stem assembly. Note: It is important to inspect Disc Holder rotation. If it does not rotate freely, do not use valve but consult your local dealer for instructions. Remove old Body Gasket (15).
- Step 2: Secure Bonnet (5) in a bench vise and remove Handwheel Nut (1), Handwheel Washer (20), and Handwheel (2).
- Step 3: Remove Disc Nut (9) and Disc (8).
- Step 4: Remove Packing Nut (4), Chevron Packing (11), Male Adapter (12), Packing Spring (14) and Packing Nut Gasket (13) over the end of Stem (3).
- Step 5: Rotate Stem (3) clockwise (CW) using Handwheel (2) if necessary, until stem is disengaged from Bonnet (5).
- Step 6: Before reassembly, clean and inspect the valve seat at (A). Clean all metal components with solvent and wipe or blow dry with air.

Assembly Procedure

REFER TO FIGURE 1 FOR THE FOLLOWING STEPS:

- Step 1: Install Disc (8), [with injection marks against the Disc Holder (7)], and Disc Nut (9) to Disc Holder (7). Secure Disc Nut (9) to threads of Disc Holder (7) with center punch mark at thread interface.
- Step 2: Lubricate threads of stem with a good quality grease and install Stem (3) into Bonnet (5) until Disc Holder (7) rests against bottom of bonnet.
- Step 3: With the bonnet and stem assembly secured in a bench vise install Packing Nut Gasket (13) and Packing Spring (14).
- Step 4: Replace O-ring (10) in groove of Packing Nut (4).
- Step 5: Install Chevron Packing (11) and Male Adapter (12) into Packing Nut (4).
- Step 6: Lubricate exposed surface of Stem (3) with John Crane Style 279A Packing Lubricant or equal.
- Step 7: Place block under Disc Holder (7) to keep stem and disc holder assembly from backing out when installing packing nut assembly to bonnet (5). Place Packing Nut (4) with packing in place over Stem (3) and engage bonnet threads in Bonnet (5). Rotate Packing Nut (4) while making contact with bonnet threads. Tighten packing nut with torque wrench to 55 ft-lbs.
- Step 8: Secure Body (16) in vise. Place Body Gasket (15) onto body.
- Step 9: Place bonnet assembly on top of Body making sure that all four bolt Holes line up, install four bolts and tighten the bolts with torque wrench to 95 ft-lbs.
- Step 10: Install Handwheel (2), Handwheel Washer (20) and tighten Handwheel Nut (1) on Stem (3).
- Step 11: Check stem packing and valve seat for leaks. Operate handwheel full open to full closed to insure smooth operation.

(OVER)

REFER TO FIGURE 1 FOR THE FOLLOWING STEPS:

- Step 1: To install valve, line up bolt holes of valve to bolt holes of mating flange. With flange gaskets in place, insert bolts through flange holes and secure with nuts. Pressurize tank with air and check for leaks. If leaks are present, do not use valve but consult your local dealer for instructions.

Safety Tips for Shut-down and Storage

SAFETY TIPS FOR SHUT-DOWN AND STORAGE WHEN TANKS ARE NOT IN USE:

- Step 1: Make sure all valves are closed with any exposed outlets / inlets capped to keep out debris and moisture, which will help to prevent condensation or corrosion of internal parts.
- Step 2: Store tanks in accordance with federal, state, and local codes and manufacturer's instructions. Check periodically for leakage or excessive pressure build-up. Make corrections or repairs as necessary.

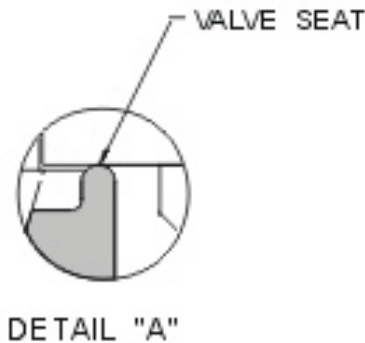

		AVAILABLE KITS		
NUMBERS	NAME & PARTS INCLUDED	ASSEMBLY PROCEDURE		
21	WARNING LABEL	320-002	SCALING KIT ① ② ③ ④ ⑤ ⑥ ⑦ ⑧ ⑨ ⑩ ⑪ ⑫ ⑬ ⑭ ⑮ ⑯ ⑰ ⑱ ⑲ ⑳ ㉑	STEPS 1 THRU 11
20	HANDWHEEL WASHER			
19	4 3/4-10 x 1 1/2" HEX HD BOLT			
18	1 1/4" NPT HEX HD. PLUG			
17	1 RETAINING SCREW	320-100	STOP & DISC HOLDER ASSEMBLY ① ② ③ ④ ⑤ ⑥ ⑦ ⑧ ⑨ ⑩ ⑪ ⑫ ⑬ ⑭ ⑮ ⑯ ⑰ ⑱ ⑲ ⑳ ㉑	STEPS 2 THRU 11
16	1 BODY			
15	1 BODY GASKET			
14	1 PACKING SPRING			
13	1 GASKET	320-1100	CONNECT ASSEMBLY ① ② ③ ④ ⑤ ⑥ ⑦ ⑧ ⑨ ⑩ ⑪ ⑫ ⑬ ⑭ ⑮ ⑯ ⑰ ⑱ ⑲ ⑳ ㉑	STEPS 8 THRU 11
12	1 MALE ADAPTER			
11	2 CHEVRON PACKING			
10	1 O-RING			
9	1 DISC NUT			
8	1 DISC			
7	1 DISC HOLDER			
6	18 BALL			
5	1 BONNET			
4	1 PACKING NUT			
3	1 STEM			
2	1 HANDWHEEL			
1	1 HANDWHEEL NUT			
ITEM	QTY	DESCRIPTION		

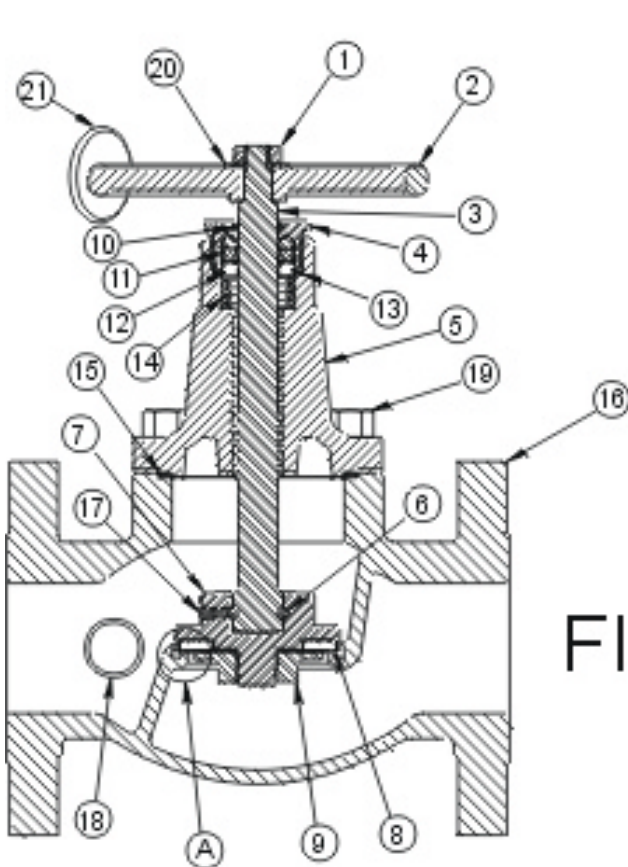

MODEL AI 320FP

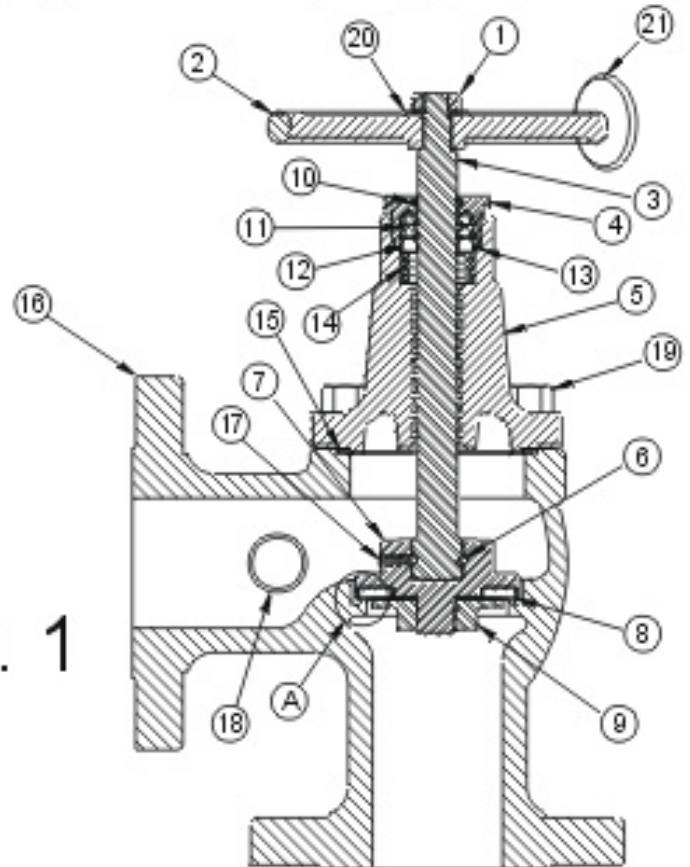

MODEL AI 321FP

FIG. 1