

November 2002

299H Series Pressure Reducing Regulators

Introduction



WARNING

Installation, operation, and maintenance procedures performed by unqualified personnel may result in improper adjustment and unsafe operation. Either condition may result in equipment damage or personal injury. Use qualified personnel when installing, operating, and maintaining the 299H Series regulators.

Scope of Manual

This instruction manual provides installation, adjustment, and maintenance instructions, and a parts list for the 299H Series regulators. Complete instructions and parts lists for the 67 Series filtered pilot supply regulator, and other Fisher equipment are found in separate instruction manuals.

Description

The 299H Series pressure reducing regulators provide a broad capacity for controlled pressure ranges and capacities in a wide variety of distribution, industrial, and commercial applications. A 299H Series regulator has a pilot integrally mounted to the actuator casing. The 299H Series regulators can handle inlet pressures up to 175 psi (12,1 bar) depending on orifice size.

The integral token relief on the Type 299HR regulator is located in the pilot and opens to relieve minor overpressure conditions.

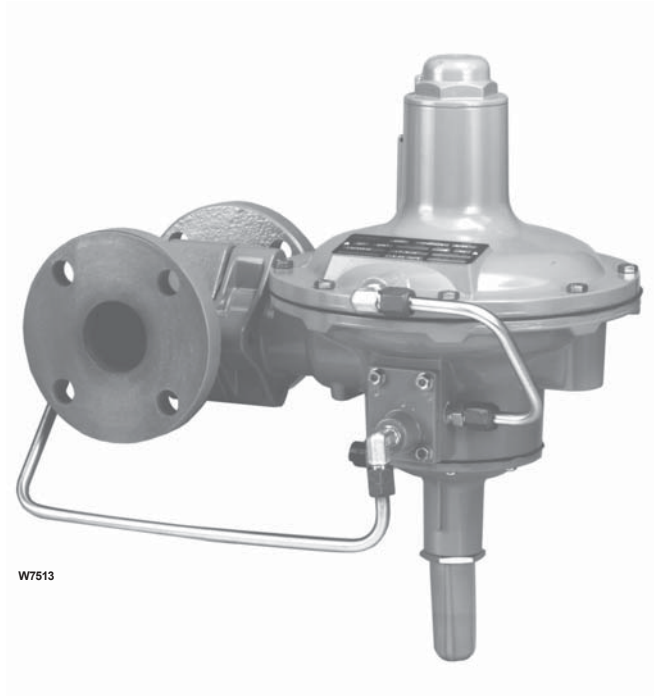

Figure 1. 299H Series Pressure Reducing Regulator

Specifications



WARNING

Since a pilot-operated regulator is constructed of both a pilot and a main valve, do not exceed the maximum inlet pressure shown on the nameplate.

Specifications for 299H Series constructions are given on page 2. Some specifications for a given regulator as it originally comes from the factory are stamped on a nameplate located on the actuator upper casing.



299H Series

Specifications

Available Configurations

Type 299H: Pilot-Operated pressure reducing regulator with a pilot integrally mounted to the actuator casing

Type 299HR: A Type 299H with a token internal relief valve to relieve minor overpressure caused by thermal expansion.

Body Size And End Connection Styles

See table 1

Maximum Operating Pressure⁽¹⁾ by Orifice Size

1/4 x 3/8-inch (6,4 x 9,5 mm)	175 psig (12,1 bar)
3/8-inch (9,5 mm)	175 psig (12,1 bar)
1/2-inch (12,7 mm)	175 psig (12,1 bar)
3/4-inch (19,1 mm)	150 psig (10,3 bar)
7/8-inch (22,2 mm)	125 psig (8,6 bar)
1-inch (25,4 mm)	100 psig (6,9 bar)
1-3/16-inch (30,2 mm)	80 psig (5,5 bar)

Maximum Emergency Outlet Pressure⁽¹⁾

66 psig (4,6 bar)

Outlet (Control) Pressure Ranges⁽¹⁾⁽²⁾

See table 2

Pressure Control Accuracy (Fixed Factor)(PFM)

±1%⁽³⁾ of absolute control pressure

Minimum Differential Pressure For Full Stroke

1.5 psi (0,10 bar)

Control Line Connections

3/4-inch NPT

Temperature Capabilities⁽¹⁾

-20° to 150°F (-29° to 66°C)

Approximate Weight

21 pounds (9,5 kg)

Fixed Restriction Sizes

0.044-inch (1,12 mm), red (**standard gain**)

0.071-inch (1,80 mm), green (low gain)

0.082-inch (2,08 mm), blue (lower gain)

Options

- **Filter⁽³⁾:** A P590 Series filter installed in the pilot supply tubing between main body and pilot
- **Filtered pilot supply regulator⁽³⁾⁽⁴⁾:** A 67 Series supply regulator with an internal 40 micron filter

1. The pressure/temperature limits in this manual and any applicable standard or code limitation should not be exceeded.
 2. For optimum performance, a pilot supply regulator may be installed in the pilot supply tubing between the main valve and pilot.
 3. For inches w.c. use a pilot supply regulator if actual inlet pressure varies more than ±20 psi (±1,4 bar) and published accuracy is required.
 4. A pilot supply regulator or a P590 Series filter (only one may be used, not both) may be ordered with the Type 299H, but not both.

Table 1. Body Sizes and End Connection Styles

BODY SIZE, INCHES (DN)	BODY MATERIAL AND END CONNECTION STYLE		
	Cast Iron	Ductile Iron	Steel
1-1/4 (32)	NPT screwed	---	---
1-1/2 (40)	NPT screwed	NPT screwed	NPT screwed
2 (50)	NPT screwed; ANSI Class 125 ⁽¹⁾ FF and 250 RF flanged	NPT screwed; ANSI Class 125 FF and 250 RF flanged; and PN 10 and 16 flanged	NPT screwed; ANSI Class 150 RF and 300 RF flanged; and PN 16 flanged

1. This flange is available with a face-to-face dimension of 7.5-inches (191 mm) or 10-inches (254 mm).

Table 2. Outlet Pressure Ranges

OUTLET (CONTROL) PRESSURE RANGE	TYPE NUMBER		PILOT CONTROL SPRING			
	299H	299HR	Part Number	Color	Free Length, Inches (mm)	Wire Diameter, Inches (mm)
3.5 to 6-inches w.c. (9 to 15 mbar) ⁽¹⁾	X	X	T13707T0012	Black	1.86 (47,2)	0.055 (1,4)
5 to 9-inches w.c. (12 to 22 mbar) ⁽¹⁾	X	X	T13589T0012	Yellow	2.05 (52,0)	0.051 (1,3)
7 to 20-inches w.c. (17 to 49 mbar) ⁽¹⁾	X	X	1N3112X0012	Silver	2.18 (55,4)	0.075 (1,9)
16 to 40-inches w.c. (40 to 99 mbar) ⁽¹⁾	X	X	1B413727222	Purple	2.12 (53,8)	0.092 (2,3)
1 to 3.25 psig (0,069 to 0,22 bar)	X	X	T13593T0012	Light blue	2.12 (53,8)	0.105 (2,7)
2.75 to 6 psig (0,19 to 0,41 bar)	X	X	T13671T0012	Orange	2.40 (61,1)	0.120 (3,0)
5 to 16 psig (0,34 to 1,10 bar)	X		T13600T0012	Red	2.10 (53,3)	0.142 (3,6)
14 to 35 psig (0,97 to 2,4 bar)	X		T13771T0012	Zinc	2.15 (54,6)	0.207 (5,3)
30 to 60 psig (2,07 to 4,14 bar)	X		T14096T0012	Green	2.75 (69,9)	0.225 (5,7)

1. Use a pilot supply regulator if actual inlet pressure varies more than ±20 psi (1,4 bar) and the published accuracy is required.

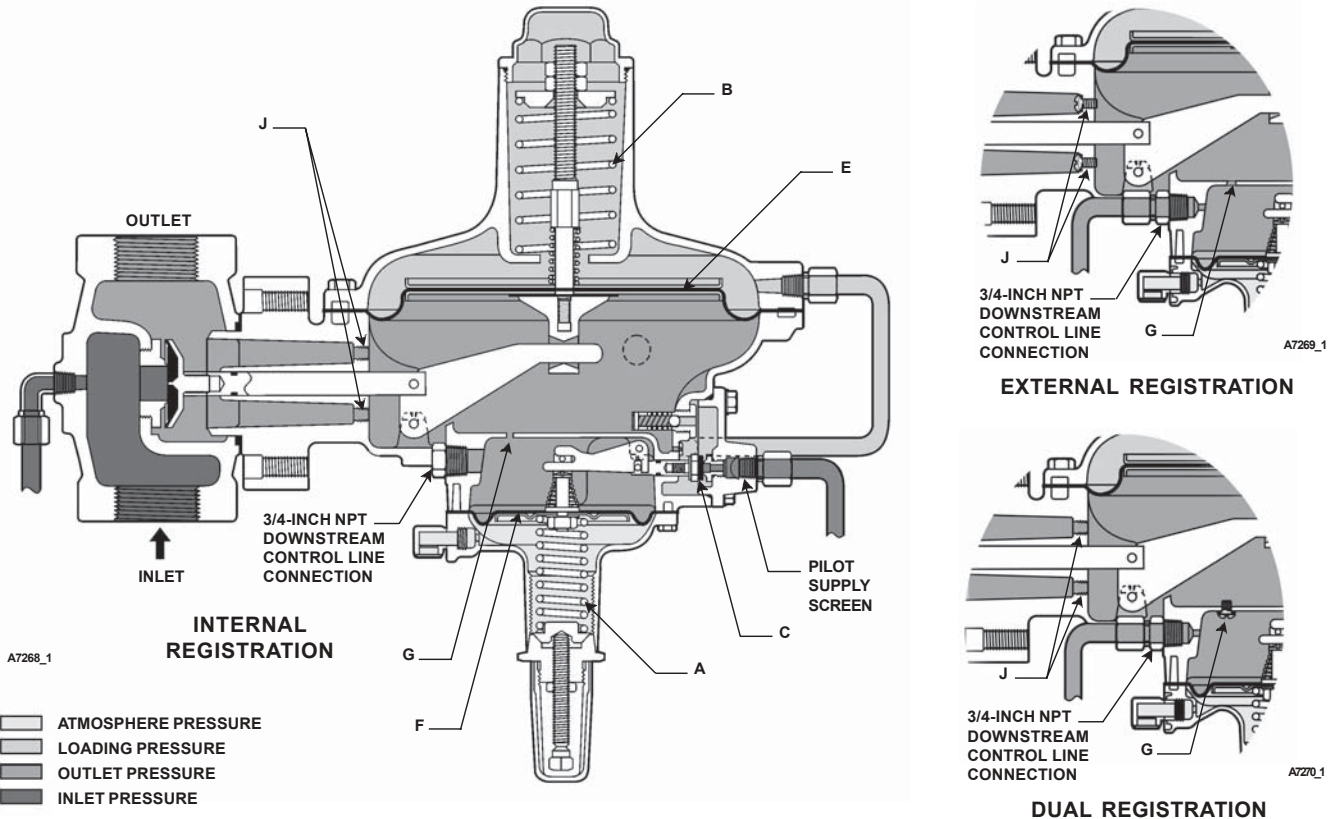

Figure 2. 299H Series Operational Schematic

Principle of Operation

Letter keys in this section refer to figure 2 unless otherwise noted. Fast response and accuracy are made possible by the amplifying effect of the pilot and by the two-path control system. The function of the pilot is to sense change in the controlled pressure and amplify it into a larger change in the loading pressure. Any changes in outlet pressure act quickly on both the actuator diaphragm and the loading pilot, thus providing the precise pressure control that is characteristic of a two-path piloting system.

Upstream or inlet pressure is utilized as the operating medium, which is reduced through pilot operation to load the main diaphragm chamber. Tubing connects the inlet pressure to the pilot. Downstream or outlet pressure registers underneath the main diaphragm (E) and on top of pilot diaphragm (F). There are three different versions of registration for the 299H Series.

Internal registration—Outlet pressure is registered through the throat to the main diaphragm chamber and then through a small port (G) to the top of the pilot diaphragm.

External registration—The throat is blocked and a downstream control line is connected to the pilot upper

diaphragm chamber or the actuator lower diaphragm chamber. A small port (G) connects the two chambers.

Dual registration—The lower main diaphragm chamber registers outlet pressure through the throat and the upper pilot diaphragm chamber registers downstream pressure by using a downstream control line. The port (G) between the chambers is blocked.

In operation, assume the outlet pressure is less than the setting of the pilot control spring (A). The top side of pilot diaphragm assembly (F) will have a lower pressure than the setting of the control spring (A). The control spring (A) forces the diaphragm assembly upward, opening the pilot orifice (C). Additional loading pressure is supplied from the pilot orifice to the top side of the main diaphragm (E).

This creates a higher pressure on the top side of the main diaphragm (E) than on the bottom side, forcing the diaphragm downward. This motion is transmitted through a lever, which pulls the valve disk open, allowing inlet pressure to flow through the valve.

When the demand in the downstream system has been satisfied, the outlet pressure increases. The increased pressure is transmitted through the downstream control line and acts on top of the pilot diaphragm (F). This

299H Series

pressure exceeds the pilot spring setting and forces the diaphragm down, closing the orifice (C). The loading pressure acting on the main diaphragm (E) bleeds to the downstream system through a bleed restriction (H).

With a decrease in loading pressure on top of the main diaphragm (E), the main closing spring (B) exerts an upward force on the diaphragm post which is connected to the main diaphragm (E), pulling it upward. This moves the main valve disk toward its seat, decreasing flow to the downstream system.

Type 299HR

During normal operation the Type 299HR performance is identical to the Type 299H. If an overpressure condition occurs, the pilot diaphragm head will separate from the pilot diaphragm post and travel until it contacts the pilot spring case. The movement of the diaphragm head creates a path and a token, or small amount of gas will be released.

When the overpressure condition ceases the pilot diaphragm head will return to the diaphragm post, and the regulator will return to normal operation.

Installation



WARNING

Personal injury, equipment damage, or leakage due to escaping gas or bursting of pressure-containing parts might result if this regulator is overpressured or is installed where service conditions could exceed the limits for which the regulator was designed, or where conditions exceed any ratings of the adjacent piping or piping connections. To avoid such injury or damage, provide pressure-relieving or pressure-limiting devices (as required by the appropriate code, regulation, or standard) to prevent service conditions from exceeding those limits.

A regulator may vent some gas to the atmosphere in hazardous or flammable gas service. Vented gas might accumulate and cause personal injury, death or property damage due to fire or explosion. Vent a regulator in hazardous gas service to a remote, safe location away from air intakes or any hazardous location. Protect the vent line or stack opening against condensation or clogging.

If the regulator is exposed to an over-pressure condition, it should be inspected for any damage that may have occurred. Operation below these limits does not preclude the possibility of damage from external sources or from debris in the pipeline.

Like most regulators, the 299H Series regulators have an outlet pressure rating lower than its inlet pressure rating. Complete downstream overpressure protection is needed if the actual inlet pressure can exceed the regulator outlet pressure rating or the pressure ratings of any downstream equipment. Regulator operation within ratings does not preclude the possibility of damage from external sources or from debris in the lines. A regulator should be inspected for damage periodically and after any overpressure condition.

Clean out all pipelines before installation and check to be sure the regulator has not been damaged or collected foreign material during shipping.

Apply pipe compound to the male pipe threads only with a screwed body, or use suitable line gaskets and good bolting practices with a flanged body. This regulator may be installed in any position desired as long as the flow through the body is in the direction indicated by the arrow on the body. Install a three-valve bypass around the regulator if continuous operation is necessary during maintenance or inspection.

Although the standard orientation of the actuator and pilot to the main valve body is as shown in figure 1, this orientation may be changed in 90° intervals rotating the actuator lower casing (key 1) 90°, rotate the elbow fitting in the same direction, and reinstalling the cap screws. To keep the pilot spring case from being plugged or the spring case from collecting moisture, corrosive chemicals, or other foreign material, the vent must be pointed down, oriented to the lowest possible point on the spring case, or otherwise protected. Vent orientation may be changed by rotating the pilot spring case with respect to the pilot body.

To remotely vent the pilot, remove the screwed-in vent assembly (key 27) from the pilot spring case and install obstruction-free tubing or piping into the 1/4-inch NPT vent tapping. Provide protection on a remote vent by installing a screened vent cap into the remote end of the vent pipe.

An upstream pilot supply line is not required because of the integral pilot supply tubing (key 21). However, as long as the 1/4-inch NPT tapping in the main valve body is plugged, this tubing may be disconnected from

the main valve (key 17) in order to install a pilot supply line from a desired remote location into the pilot.

If using a control line, attach the control line from the pilot tap two to three feet (0,6 to 0,9 meters) downstream of the regulator in a straight run of pipe. If impossible to comply with this recommendation due to the pipe arrangement, it may be better to make the control line tap nearer the regulator outlet rather than downstream of a block valve. Do not make the tap near any elbow, swage, or nipple which might cause turbulence. For optimal performance, use as large of a control line as practical.

In many instances, it will be necessary to enlarge the downstream piping to keep flow velocities within good engineering practices. Expand the piping as close to the regulator outlet as possible.



WARNING

Adjustment of the pilot control spring to produce an outlet pressure higher than the upper limit of the outlet pressure range for that particular spring can cause personal injury or equipment damage due to bursting of pressure-containing parts or the dangerous accumulation of gases if the maximum actuator emergency casing pressure is exceeded. If the desired outlet pressure is not within the range of the pilot control spring, install a spring of the proper range according to the Maintenance section.

Each regulator is factory-set for the pressure setting specified on the order. If no setting was specified, the outlet pressure was set midrange of the pilot control spring. In all cases, check the control spring setting to make sure it is correct for the application.

Registration Conversion

To convert the Type 299H regulators from one type of registration to another all that is required is adding or removing screws and O-rings.

To change an internal registration regulator to an external registration regulator with a downstream control line, block the two ports in the throat with screws and O-rings (J in figure 2). Remove either the 3/4 inch NPT pipe plug in the pilot casing or the 3/4-inch NPT pipe plug in the lower casing and add a downstream control line.

To convert an external registration regulator to a dual registration regulator, remove the two screws and O-rings (J in figure 2) from the throat and use a screw

and an O-ring to block the port (G in figure 2) between the lower diaphragm chamber and pilot diaphragm chamber. Remove the 3/4-inch NPT pipe plug in the pilot lower casing and add a downstream control line.

Startup

With proper installation completed and downstream equipment properly adjusted, perform the following procedure while monitoring the pressure with gauges.

1. Very slowly open the upstream block valve.
2. Slowly open the hand valve (if used) in the control line. The regulator will control downstream pressure at the pilot control spring setting. See the Adjustment section following these numbered steps if changes in the setting are necessary during the startup procedure.
3. Slowly open the downstream block valve.
4. Slowly close the bypass valve, if used.
5. Check all connections for leaks.

Adjustment

Keys are referenced in figure 4. The only adjustment on the regulator is the reduced pressure setting affected by the pilot control spring (key 32). Remove the closing cap (key 29) and turn the adjusting screw (key 36). Turning the adjusting screw clockwise into the spring case increases the controlled or reduced pressure setting. Turning the screw counterclockwise decreases the reduced pressure setting. Always tighten the locknut (key 35) and replace the closing cap after making adjustments.

Shutdown

Installation arrangements may vary, but in any installation it is important to open and close valves slowly and the outlet pressure be vented before venting inlet pressure to prevent damage caused by reverse pressurization of the regulator. Isolate the regulator from the system. Vent the downstream pressure; then vent inlet pressure to release any remaining pressure in the regulator.

Maintenance

Regulator parts are subject to normal wear and must be inspected periodically and replaced as necessary. The frequency of inspection and replacement depends upon the severity of service conditions and upon applicable codes and government regulations.

Due to the care Fisher takes in meeting all manufacturing requirements (heat treating, dimensional

299H Series

tolerances, etc.), use only replacement parts manufactured or furnished by Fisher.



WARNING

Avoid personal injury or damage to property from sudden release of pressure or uncontrolled gas or other process fluid. Before starting to disassemble, carefully release all pressures according to the Shutdown procedure. Use gauges to monitor inlet, loading, and outlet pressures while releasing these pressures.

On reassembly of the regulator, it is recommended that a good quality pipe thread sealant be applied to pressure connections and fittings and a good quality lubricant be applied to all O-rings. Also apply an anti-seize compound to the adjusting screw threads and other areas as needed.

Note

The regulator body may remain in the pipeline during maintenance procedures.

Main Actuator Diaphragm

Follow this procedure to change the actuator diaphragm, or to inspect, clean, or replace any other parts in the main actuator. Part key numbers are referenced in figure 5.

1. Cut the wire seal (being careful not to lose the warning tag) and remove the closing cap (key 3). Inspect the O-ring (key 9) and replace if necessary.
2. Carefully loosen and remove the double nuts (key 5) on the actuator diaphragm post (key 10). When removing the adjusting nuts, do not twist or unscrew the diaphragm post, as this action will loosen the joint between the diaphragm post and the pusher post (keys 10 and 11).
3. Remove the spring seat (key 4) and closing spring (key 6).
4. Remove the eight hex head cap screws (key 23) and lift off the upper casing (key 2).
5. Remove the diaphragm assembly (key 8) by tipping it so that the lever (key 26) slips out of the pusher post (key 11).
6. Separate the diaphragm assembly by unscrewing the diaphragm post (key 10) from the pusher post

(key 11) and remove the diaphragm post, pressure equalization spring (key 7), diaphragm head (key 81), diaphragm (key 8), the second diaphragm head (key 81), and diaphragm pad (key 80). Inspect the diaphragm parts for damage and replace if necessary.

7. Inspect the lever (key 26) and replace if necessary. To replace the valve stem (key 16), also perform Main Body Valve Disk and Orifice maintenance procedure steps 1, 2, and 3, remove disk, and pull the stem out of the lower casing assembly (key 1). Lightly lubricate the replacement stem O-ring (key 14) and install it on the valve stem. Reinstall the valve stem into the lower casing assembly. Reinstall the body or continue with the reassembly of the diaphragm.

Note

When assembling the diaphragm assembly (keys 8, 80, and 81), lubricate the actuator diaphragm post (key 10) threads.

8. Loosely reassemble the diaphragm and diaphragm post parts so that the bolt holes in the diaphragm align with the corresponding holes in the lower casing (key 1) when the lever (key 26) is fitted properly into the pusher post. When this orientation is made, tighten the diaphragm post into the pusher post (keys 10 and 11).
9. Reinstall the diaphragm assembly using the reverse order of step 5.
10. Install the upper casing (key 2) and secure it to the lower casing (key 1) with the eight hex head screws. Tighten the hex head screws evenly using a crisscross pattern to avoid placing a uneven strain on the regulator. Tighten the screws to a final bolt torque of 10 to 13 foot-pounds (13 to 17 N•m) to avoid crushing the diaphragm.



CAUTION

In step 11, the spring seat (key 4) is under spring pressure. Use constant hand pressure to hold the spring down when installing the hex nuts (key 5).

11. Install the closing spring (key 6) and the spring seat (key 4). Push and hold down on the spring seat, cocking it to one side until the seat catches onto the threads of the diaphragm post. Then, pull up on the diaphragm post allowing access to the post threads so that the adjusting two hex nuts (key 5) can be installed. Install the adjusting hex nuts as shown in figure 5.

The closing spring must be adjusted down to a depth of 1/2 inch (12,7 mm) from the top of the upper case

opening to the top of the spring seat (see figure 3). When tightening the two hex nuts, use care not to rotate the diaphragm post, which may damage the post.

12. Lightly lubricate the O-ring (key 9) on the closing cap and reinstall the closing cap (key 3).



WARNING

The seal and warning tag (keys 68 and 69) contain important safety information, make sure they are attached when maintenance is completed.

13. Install the seal and warning tag (keys 68 and 69).

Main Body Valve Disk and Orifice

Follow this procedure to inspect, clean, or replace the main body valve disk or to inspect or replace the orifice. Part key numbers are referenced in figure 5.

Note

The regulator body may remain in the pipeline during maintenance procedures.

1. Disconnect the pilot supply tubing (key 21) from the main body (key 17).

2. Remove the two hex head cap screws (key 18) which hold the lower casing (key 1) to the body. Separate the lower casing from the body. Inspect the body O-ring and replace if worn or damaged.

3. Examine the valve disk (key 13) and orifice (key 12) for nicks, cuts, and other damage. Unscrew the disk holder assembly from the valve stem assembly (key 16) and replace it with a new part if necessary.

If the orifice is being replaced with a new or different size orifice, change the nameplate (key 63) to state the new size and maximum inlet pressure. Lubricate the threads and flat face of the orifice with a good grade of anti-seize lubricant. Install the orifice using 75 to 100 foot-pounds (102 to 136 N•m) of torque.

4. After replacing all damaged parts, slide the entire assembly into the valve body and secure with the two hex head cap screws.

5. Connect the pilot supply tubing, then refer to the Startup section for putting the regulator into operation.

Integral Pilot Valve Disk and Orifice

Follow this procedure to inspect, clean, or replace the integral pilot valve disk or orifice. Part key numbers are referenced in figures 4 and 6.

1. Remove or loosen the pilot supply tubing (key 21).

2. Remove the inlet fitting (key 47), remove the four machine screws (key 46).

3. Examine the valve disk (key 52) for nicks, cuts, and other damage. Unscrew the disk holder assembly from the valve stem and replace if necessary.

4. If the seating edge of the orifice (key 50) is nicked or rough, use a thin-walled socket to remove the orifice from the inlet fitting (key 47). Install a new orifice and a lightly lubricated O-ring when reassembling the regulator.

5. Inspect the check valve assembly (key 45) and the bleed restriction (key 70) for damage and replace if necessary.

6. The Type 299H has a wire inlet screen (key 51) in the pilot supply inlet fitting (key 47). If clogging is suspected in the pilot supply, remove the elbow fitting and clean the wire screen.

7. Lightly lubricate the O-ring (key 54) on the inlet fitting (key 47) and reinstall using the four machine screws (key 46). Torque the machine screws to 30 to 40 inch-pounds (3,4 to 4,5 N•m). Then install and tighten the pilot supply tubing.

Integral Pilot Control Spring and Diaphragm

Follow this procedure to change the pilot control spring or to inspect, clean, or replace the diaphragm. Part key numbers are referenced in figure 4 and 6.

1. Remove the pilot closing cap (key 29) and loosen the hex lock nut (key 35). Turn the adjusting screw (key 36) counterclockwise to ease spring compression.

2. Unscrew the bonnet (key 34).

3. Remove the bonnet (key 34), spring seat (key 33), and control spring (key 32).

4. If only replacing the control spring, sparingly apply lubricant to the control spring seat (key 33) and reassemble in the reverse order.

Note

When replacing the control spring with a different spring range, be sure to delete the spring range appearing on the nameplate and indicate the new range.

5. Remove the machine screws (key 30) and spring case (key 31) from the lower casing (key 1).

6. Remove the diaphragm assembly (key 28) by tilting them so that the pusher post (key 40) slips off the lever (key 57). To separate the diaphragm from the attached

299H Series

parts, unscrew the hex nut (key 37) and separate the parts: washer (key 38), diaphragm post (key 39), pusher post (key 40), overtravel spring (key 41), machine screw (key 42), spring seat (key 88) (Type 299HR only), rivet (key 43), and retaining ring (key 44).

7. To replace the lever assembly (key 57) remove the lever pin (key 25). To replace the valve stem (key 48), also perform Integral Pilot Valve Disk and Orifice maintenance procedure steps 1, 2, and 3 and pull the stem (key 48) out of the lower casing assembly (key 1). Lightly lubricate the replacement stem O-ring (key 53) and install it on the valve stem.

8. Install the valve stem into the lower casing assembly. Be careful not to cut the O-ring (key 53) when sliding the valve stem into the lower casing.

9. Reinstall the diaphragm assembly using the reverse order of step 6.

10. Place the spring case (key 31) on the lower casing (key 1) with the vent (key 27) oriented to prevent clogging or entrance or moisture. Install the machine screws (key 30) and tighten in a crisscross pattern using 12 to 18 inch-pounds (1,4 to 2,0 N•m) of torque.

11. When all maintenance is complete, refer to the Startup section to put the regulator back into operation, and adjust the pressure setting. Tighten the locknut (key 35) and install the closing cap (key 29).

Optional P590 Series Filter

Figures are referenced in figure 3. If clogging is suspected in the upstream regulator passages, disconnect the pilot supply tubing (key 21), remove the filter assembly, and check for filter clogging. If necessary, to clean or replace filter parts, remove the following: filter body (key 1), machine screw (key 4), spring washer (key 6), gasket (key 7), washer (key 5), and filter element (key 2). Upon reassembly, place one flat washer between the filter element and filter head (key 3) and the other between the filter element and gasket.

Optional 67 Series Pilot Supply Regulator

For complete installation, maintenance and parts listing refer to the 67 Series instruction manual.

Parts Ordering

The type number, orifice size, spring range, and date of manufacture are stamped on the nameplate. Provide this information along with the eleven-character part number to your Fisher Representative

when ordering parts. If construction changes are made in the field, be sure that the nameplate is also changed to reflect the most recent construction.

Parts List

299H Series Regulator (figure 3)

Key	Description	Part Number
1	Lower Casing, aluminum	T80447T0012
2	Upper Casing, aluminum	T40577T0012
3	Closing Cap, aluminum	1L928308012
4	Spring Seat, steel	T13831T0012
5	Adjustment Nut, steel (2 required)	1A341224122
6	Closing Spring, steel	T13918T0012
7	Pressure Equalization Spring, steel	T13463T0012
8*	Diaphragm, nitrile	T20986T0012
9*	O-ring, nitrile	1F914106992
10	Diaphragm Post, steel	T13814T0012
11	Pusher Post, aluminum	1L143311992
12	Orifice, aluminum	
	1/4 x 3/8-inch (6,4 x 9,5 mm)	T13833T0012
	3/8-inch (9,5 mm)	1H979309022
	1/2-inch (12,7 mm)	1H979409022
	3/4-inch (19,1 mm)	1H979509022
	7/8-inch (22,2 mm)	T14098T0012
	1-inch (25,4 mm)	1H979609022
	1-3/16 (30,2 mm)	1H979709022
13*	Disk, nitrile	1P7349000A2
14*	O-ring, nitrile	1E216306992
15*	O-ring, nitrile	T12587T0012
16	Valve Stem Assembly	1L1426000A2
17	Valve Body	
	Cast Iron	
	1-1/4-inch (DN 32), NPT screwed	T40578T0012
	1-1/2-inch (DN 40), NPT screwed	1J190419012
	2-inch (DN 50)	
	NPT screwed	1H968919012
	125 FF flanged	
	7.5-inch (191 mm) face-to-face dimension	T80445T0012
	10-inch (254 mm) face-to-face dimension	2L425119012
	250 RF flanged	T40488T0012
	Ductile Iron	
	1-1/2-inch (DN 40), NPT screwed	T40561T0012
	2-inch (DN 50)	
	NPT screwed	T40562T0012
	125 FF flanged	T80424T0012
	250 RF flanged	T80425T0012
	PN 10-16 flanged	T80426T0012
	Steel	
	1-1/2-inch (DN 40), NPT screwed	1J1904T0022
	2-inch (DN 50)	
	NPT screwed	1H9689T0022
	150 RF flanged	T80415T0012
	300 RF flanged	T80416T0012
	PN 16 flanged	T80417T0012
18	Cap Screw, steel (2 required)	T14034T0012
19	Elbow, cast iron or steel bodies require 3 elbows and ductile iron bodies require 2 elbows	
	Steel	15A6002X472
	Stainless steel	15A6002X612
20	Connector	
	Cast Iron or Steel Bodies	
	Without filter and pilot supply regulator require 1 connector	
	All other combinations of filter and/or pilot supply regulator require 3 connectors.	

* Recommended spare part

Key	Description	Part Number
20	Connector (continued) Ductile Iron Bodies Without filter and pilot supply regulator require 2 connectors All other combinations of filter and/or pilot supply regulator require 4 connectors. Steel Stainless steel	15A6002X462 15A6002X602
21	Pilot Supply Tubing, Stainless steel, without filter Stainless steel, without filter ⁽¹⁾	T14247T0022 T14017T0022
22	Loading Tubing, Stainless steel	T14246T0022
23	Cap Screw, steel (8 required)	1C379124052
24	Machine Screw, steel (2 required)	1B420428982
25	Pin, lever, stainless steel (2 required)	1H972935032
26	Lever, steel	T13813T0012
27	Type Y602-12 Vent Assembly	27A5516X012
28	Diaphragm Assembly	T14259T0012
29	Closing Cap, UV resistant nylon	24B1301X012
30	Machine Screw, steel (8 required)	T14069T0012
31	Spring Case, aluminum	T14097T0012
32	Control Spring 3.5 to 6-inches w.c. (9 to 15 mbar) 5 to 9-inches w.c. (12 to 22 mbar) 7 to 20-inches w.c. (17 to 49 mbar) 16 to 40-inches w.c. (40 to 99 mbar) 1 to 3.25 psig (0,069 to 0,22 bar) 2.75 to 6 psig (0,19 to 0,41 bar) 5 to 16 psig (0,41 to 1,10 bar) (299H only) 14 to 35 psig (0,97 to 2,4 bar) (299H only) 30 to 60 psig (2,07 to 4,14 bar) (299H only)	T13707T0012 T13589T0012 1N3112X0012 1B413727222 T13593T0012 T13671T0012 T13600T0012 T13771T0012 T14096T0012
33	Spring Seat, steel	T13917T0012
34	Bonnet, steel	T14135T0012
35	Locknut, steel	1A352224122
36	Adjusting Screw, steel	T14133T0012
37	Hex Nut, steel	1E985324142
38	Washer, steel	1F230328992
39	Diaphragm Post, stainless steel Type 299H Type 299HR	T13915T0012 T14033T0012
40	Pusher Post, steel	T13914T0012
41	Overtravel Spring, stainless steel Type 299H Type 299HR	T14136T0012 T14031T0012
42	Machine Screw, steel	1A954828992
43	Rivet, flat head, stainless steel	T13916T0012
44	Retaining Ring, steel	16A6977X012
45	Check Valve Assembly	T14258T0012
46	Machine Screw, steel (4 required)	T13920T0012
47	Inlet Fitting, aluminum	T13824T0012
48	Stem Assembly	1H9666T0012
49*	O-ring, nitrile	T13939T0012
50	Pilot Orifice, aluminum	T13825T0012
51	Inlet Screen, stainless steel	T13791T0012
52*	Pilot Disk Assembly	T13955T0012
53*	O-ring, nitrile	1D682506992
54*	O-ring, nitrile	13A2331X022
56	Screw, steel (External Registration - 2 required or Dual Registration - 1 required)	1E175828982
57	Lever, steel	T14134T0012
58	Pipe Plug, steel	1A7715T0012
59	Pipe Plug, Internal Registration only, steel	1A7715T0012
61	O-ring, Nitrile (External Registration - 2 required or Dual Registration - 1 required)	17A0960X012
62	Drive Screw, steel (2 required)	1E501728982
63	Nameplate, aluminum	-----
68*	Wire Seal	T14088T0012
69	Warning Tag, aluminum	T13815T0012

Key	Description	Part Number
70	Bleed Restriction, steel 0.044-inch (1,1 mm) red (standard) 0.071-inch (1,8 mm) green 0.082-inch (2,1 mm) blue	17A2029X012 17A2030X012 17A7277X012
72	Optional P590 Series Filter	See P590 Series
76	Optional Pilot Supply Regulator	See 67 Series
78	Pilot Supply Tubing, long Stainless steel, w/ filter Stainless steel, w/ filter ⁽¹⁾	T13969T0022 T14022T0022
79	Pilot Supply Tubing, short Stainless steel, w/ filter	T13968T0022
80	Pad, nitrile	T13830T0012
81	Diaphragm Head, steel (2 required)	T13812T0012
82	Insert, aluminum ⁽¹⁾	T14013T0012
83	O-ring, nitrile ⁽¹⁾	T1072606562
84	Plate (for ductile iron body), steel ⁽¹⁾	T14039T0012
85	O-ring (for ductile iron body), nitrile ⁽¹⁾	T13769T0012
86	O-ring (for ductile iron body), nitrile ⁽¹⁾	T13772T0012
87	Set Screw (for ductile iron body) (4 required) ⁽¹⁾	1C629828992
88	Spring Seat, Type 299HR only	T14030T0012
89	Label, (not shown) Type 299H Type 299HR	T1215806032 T1215906032

Optional P590 Series Filter (Key 72)

Key	Description	Part Number
1	Filter Body Type P594-1, brass Type P593-1, aluminum	1E312414012 1E312409012
2*	Filter Element, cellulose	1E312606992
3	Filter Head Type P594-1, brass Type P593-1, aluminum	1E312514012 1E312509012
4	Machine Screw Type P594-1, brass Type P593-1, aluminum	1J500218992 1J500209012
5	Washer (2 required) Type P594-1, brass Type P593-1, aluminum	1J500018992 1J500010062
6	Spring Washer, plated carbon steel	1H885128982
7*	Gasket, composition	1F826804022

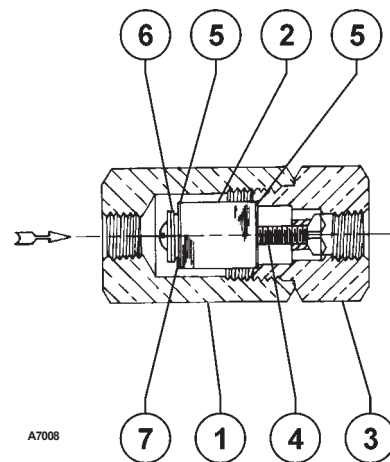

KEY 72 - OPTIONAL P590 SERIES FILTER

Figure 3. Optional P590 Series Filter

* Recommended spare part
1. Ductile iron bodies only.

299H Series

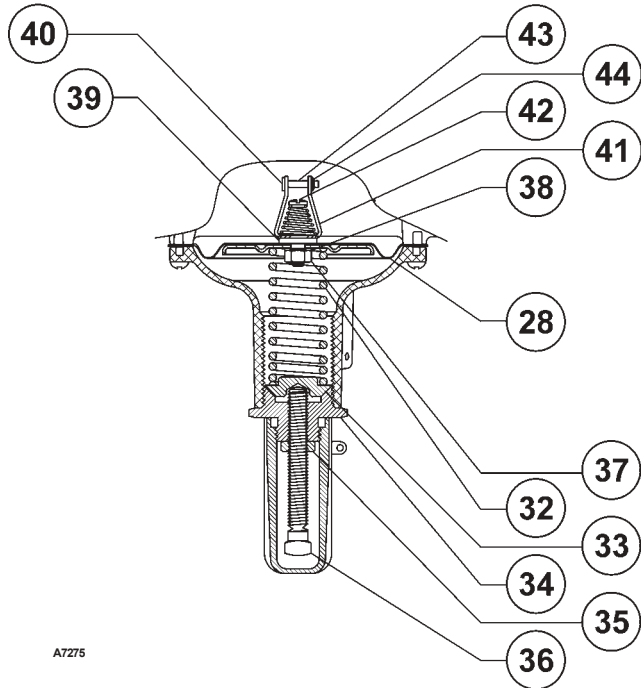

A7275

TYPE 299H PILOT (WITHOUT RELIEF VALVE)

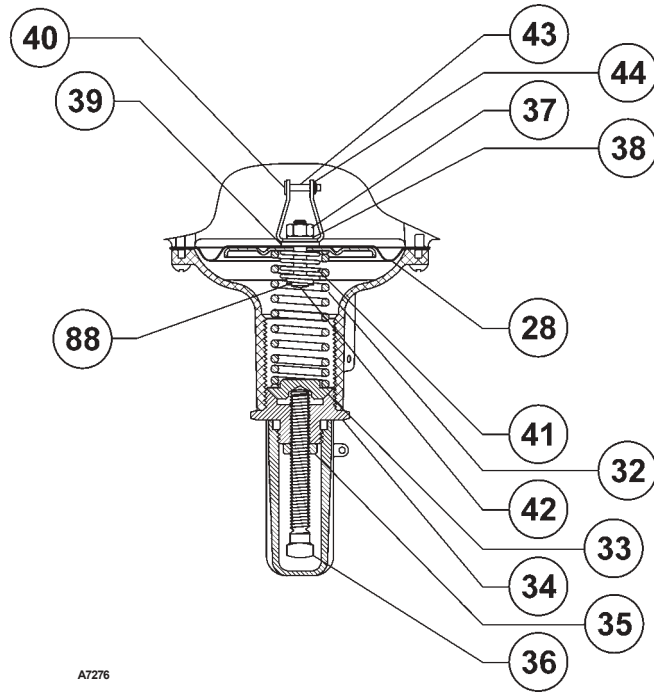

A7276

TYPE 299HR PILOT WITH TOKEN RELIEF VALVE

Figure 4. 299H Series Pilot Assemblies

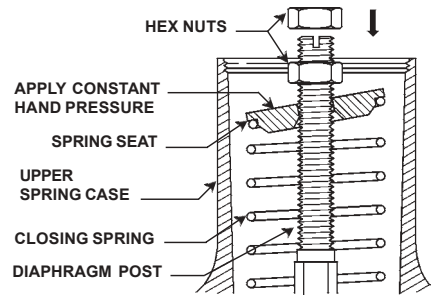

LOCKING DOWN THE SPRING SEAT TO FACILITATE INSTALLING THE HEX NUTS

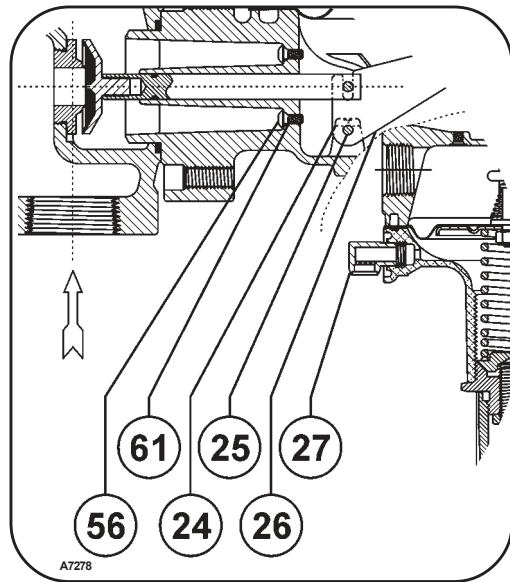

A7278

EXTERNAL REGISTRATION

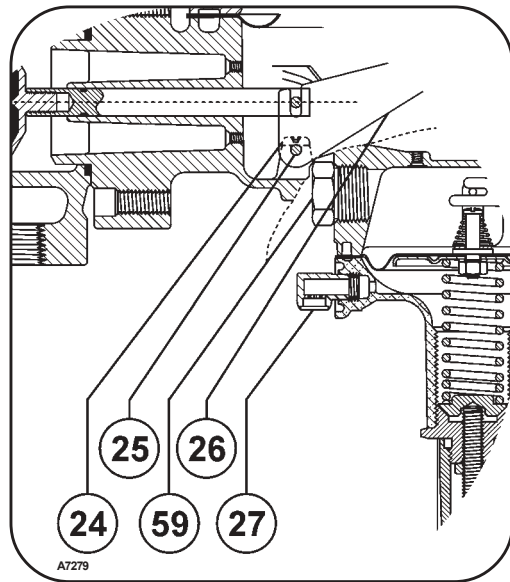

A7279

INTERNAL REGISTRATION

Figure 5. 299H Series Interior Assembly

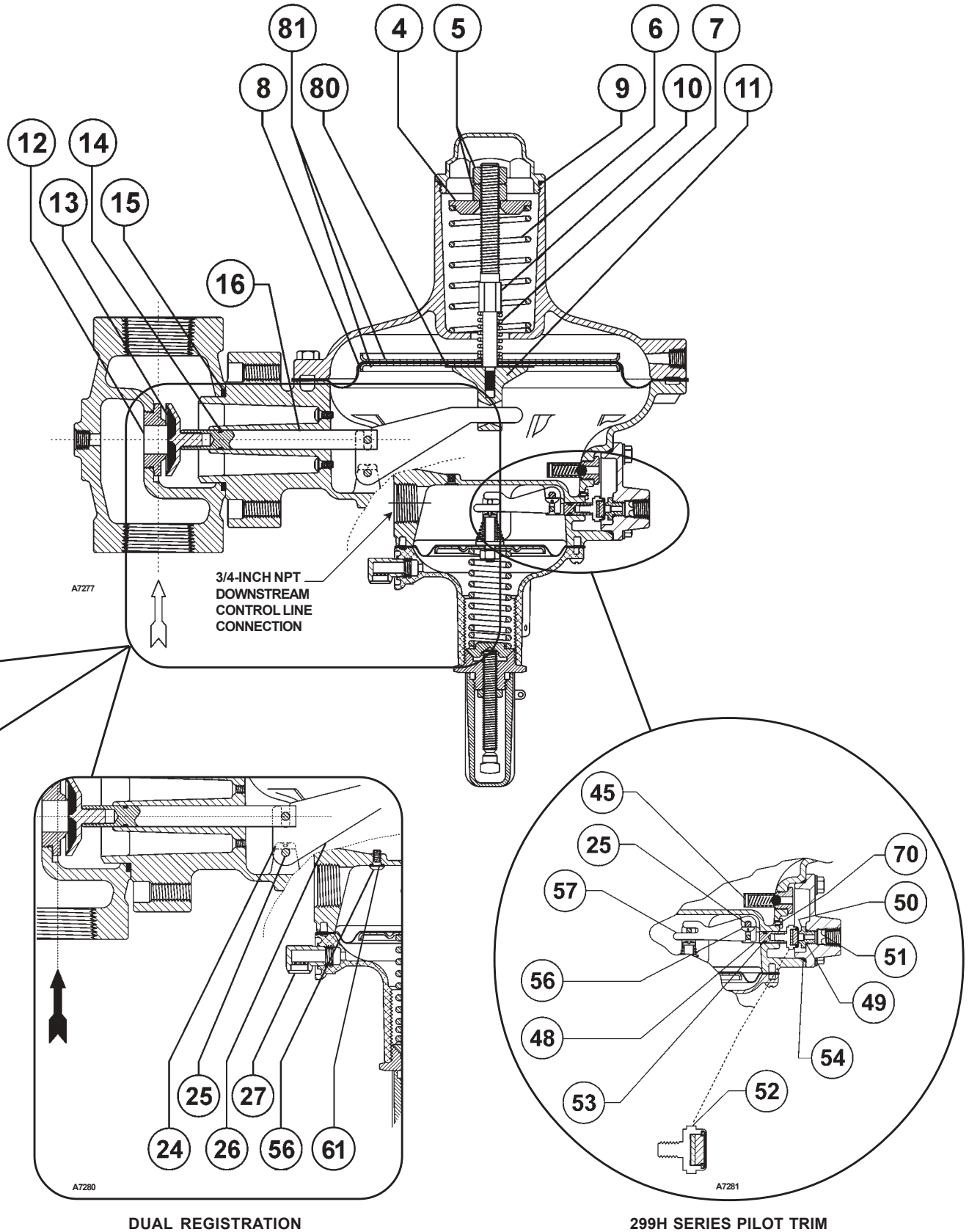
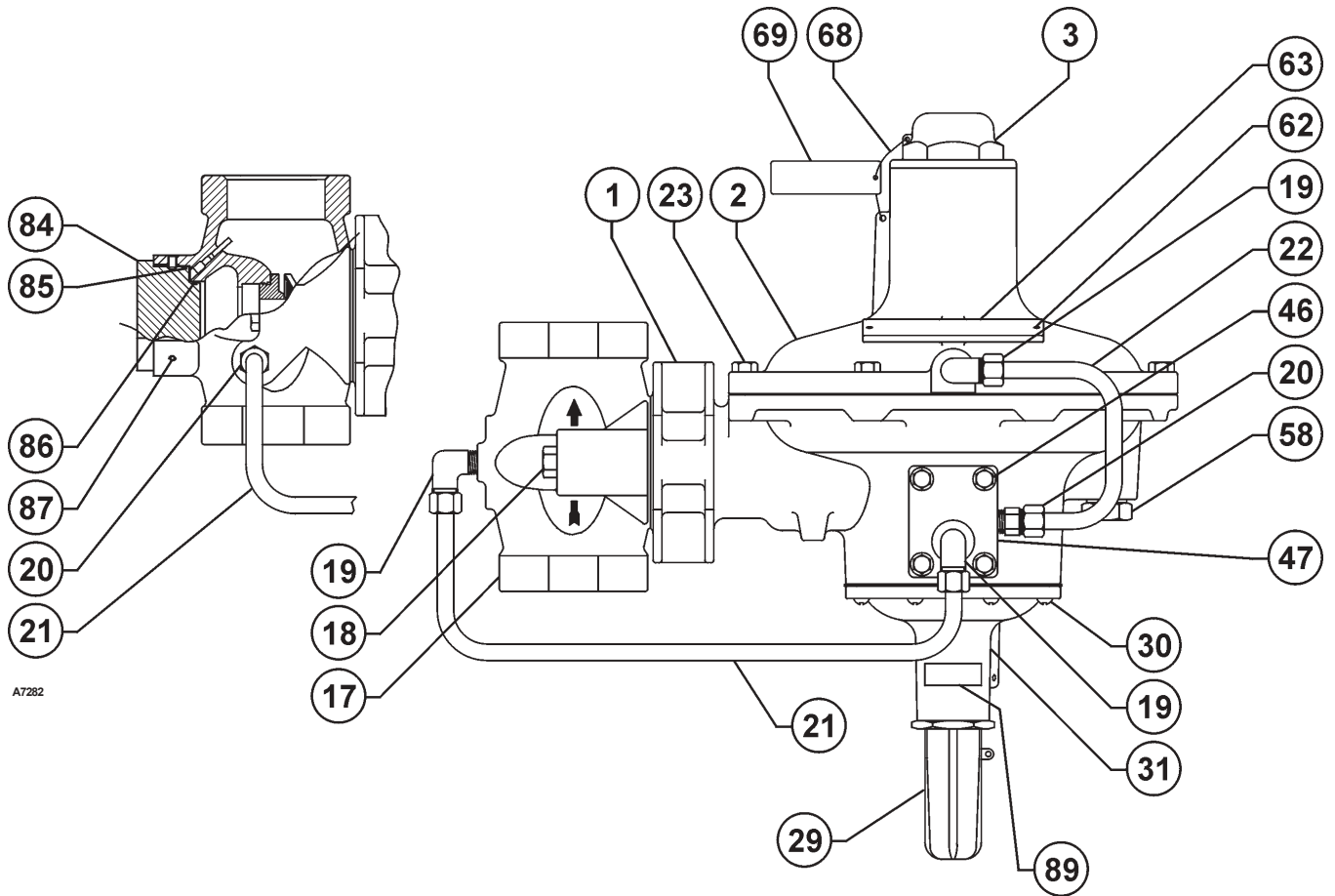

Figure 5. 299H Series Interior Assembly (continued)

299H Series



A7282

299H SERIES EXTERIOR VIEW

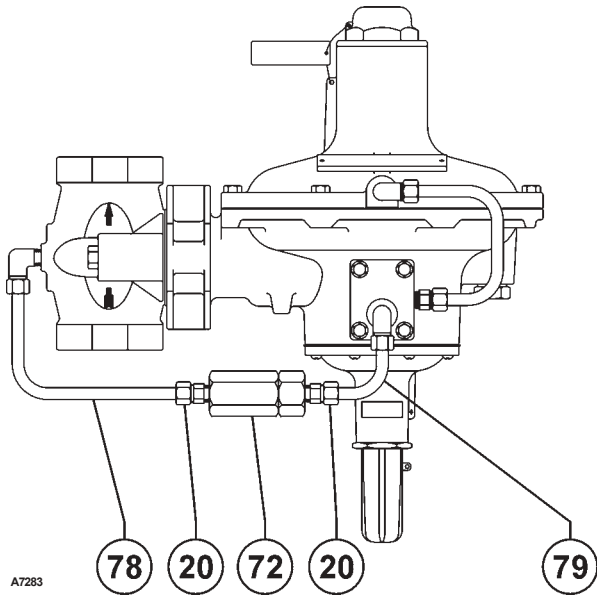

A7283

TUBING AND FITTINGS WITH
OPTIONAL TYPE P590 FILTER

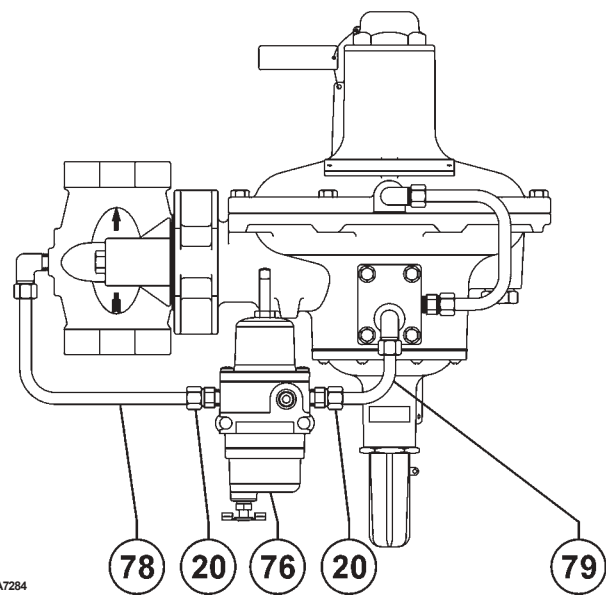

A7284

TUBING AND FITTINGS WITH
OPTIONAL 67 SERIES PILOT SUPPLY REGULATOR

Figure 6. 299H Series Exterior Assembly

January 2000

Errata Sheet for

299H Series Pressure Reducing Regulators
Form 5497, June 1999

The 299H Series is now available with an integral slam-shut device. Add the following information to the 299H Series Instruction Manual, form 5497.

- **Add the following paragraph to the Description section on page 1.**

The Type 299HS provides over or over and underpressure protection by completely shutting off the flow of gas to the downstream system. The shut-off device's actions are independent of the main valve and of variations to the inlet pressure. The slam-shut device has internal or external registration. External registration requires a downstream sensing line.

- **Add the following paragraphs to the Principle of Operation section on page 4.**

Type 299HS

The Type VSX-2 slam-shut device on the Type 299H regulator is a fast acting shut-off valve which provides over or over and underpressure protection by completely shutting off the flow of gas to the downstream system. The shut-off module's actions are independent of the Type 299H regulator and of variations to the inlet pressure. The VSX-2 has internal or external registration. External registration requires a downstream sensing line.

The shut-off disk is held in the open position (reset position) by a small ball holding the disk stem. If the pressure below the diaphragm increases (or decreases) reaching the Type VSX-2 setpoint, the diaphragm will travel upwards (or downwards) operating a lever which in turn releases the ball.

Once the ball is released, the spring force on the stem will push the stem and disk to the closed position against the seat shutting off all gas flow. The pilot supply pressure is also shut off when the Type VSX-2 is closed. The manual reset has an internal bypass to equalize the reset pressure on either side on the shut-off disk.

- **Add the following paragraph to the Installation warning on page 4.**

If the Type VSX-2 is exposed to an overpressure condition, it should be inspected for any damage that may have occurred. Operation below these limits does not preclude the possibility of damage from external sources or from debris in the pipeline.

299H Series

- Add the following information to the Specifications section on page 2.

Specifications

Available Configurations

Type 299HS: Same as the Type 299H with a Type VSX-2 shutoff valve which provides over or over and underpressure protection.

Type 299HSR: Same as the Type 299HS with an internal token relief valve.

Body Size And End Connection Styles

Note: The Type 299HS is only available in Ductile iron

Maximum Inlet Pressure⁽¹⁾ by Orifice Size

Note: The Type 299HS is not available with 7/8-inch (22,2 mm), 1-inch (25,4 mm), or 1-3/16-inch (30,2 mm) orifice

Maximum Outlet Pressure⁽¹⁾

66 psig (4,6 bar)

Maximum Set Pressure for Type 299HS⁽¹⁾

16 psig (1,1 bar)

Type 299HS Outlet (Control) Pressure Ranges⁽¹⁾

See table 1

Maximum Set Pressure for Slam-Shut Device⁽¹⁾

23 psig (1,6 bar)

Minimum and Maximum Trip Pressure Ranges

See table 2

Type VSX-2 Sensing Line Connection

1/4-inch NPT screwed

1. The pressure/temperature limits in this bulletin and any applicable standard or code limitation should not be exceeded.

- Add the following table to the instruction manual.

Table 1. Type 299HS Outlet Pressure Ranges

SPRING NUMBER	OUTLET (CONTROL) PRESSURE RANGE	PILOT CONTROL SPRING			
		Part Number	Color Code	Free Length, Inches (mm)	Wire Diameter, Inches (mm)
1	3.5 to 6-inches w.c. (9 to 15 mbar) ⁽¹⁾	T13707T0012	Black	1.86 (47,2)	0.055 (1,4)
2	5 to 9-inches w.c. (12 to 22 mbar) ⁽¹⁾	T13589T0012	Yellow	2.05 (52,0)	0.051 (1,3)
3	7 to 20-inches w.c. (17 to 49 mbar) ⁽¹⁾	1N3112X0012	Silver	2.18 (55,4)	0.075 (1,9)
4	16 to 40-inches w.c. (40 to 99 mbar) ⁽¹⁾	1B413727222	Purple	2.12 (53,8)	0.092 (2,3)
5	1 to 3.25 psig (0,069 to 0,22 bar)	T13593T0012	Light blue	2.12 (53,8)	0.105 (2,7)
6	2.75 to 6 psig (0,19 to 0,41 bar)	T13671T0012	Orange	2.40 (61,1)	0.120 (3,0)
7	5 to 16 psig (0,34 to 1,10 bar)	T13600T0012	Red	2.10 (53,3)	0.142 (3,6)

1. Use a pilot supply regulator if actual inlet pressure varies more than ± 20 psi (1,4 bar) and published accuracy is required.

- Add the following paragraphs to the Registration Conversion section on page 5.

Type VSX-2 Slam-Shut Device

To convert the Type VSX-2 from one type of registration to another all that is required is adding or removing a screw and gasket.

To change an internal registration Type VSX-2 to an external or dual registration Type VSX-2 with downstream control line, block the body pitot tube with a screw and gasket (keys 10 and 11, figure 7). Remove the pipe plug in the Type VSX-2 and add a downstream control line.

- Add the following step between steps 1 and 2 of the Startup procedure on page 5.

On a Type 299HS the Type VSX-2 is shipped in the tripped position and will need to be reset. If the Type VSX-2 is a high trip only, it can be reset before starting the regulator. If the Type VSX-2 is a high and low trip, the regulator will need to be started and the downstream system pressurized before the Type VSX-2 can be reset. See the section for Type VSX-2 reset.

- Add the following to figure 2 on page 3.

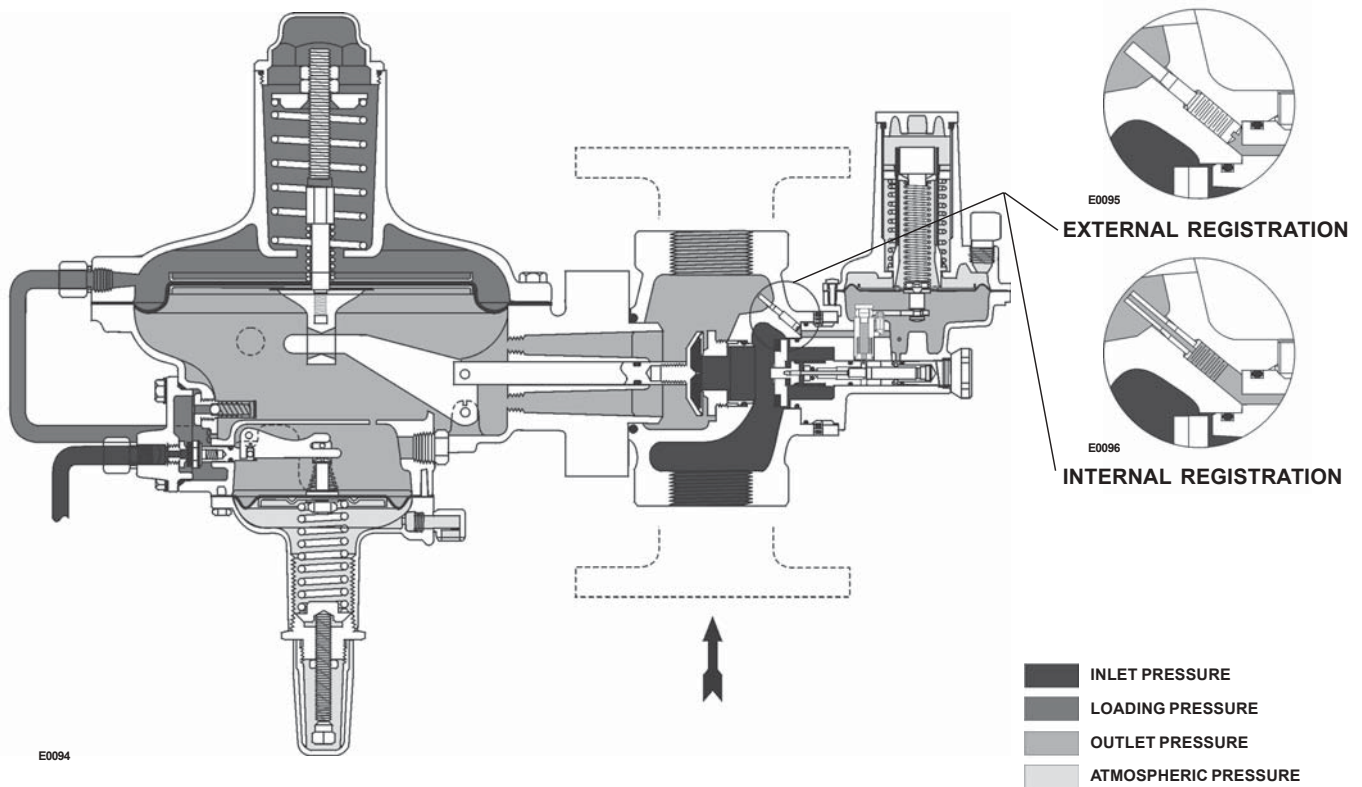

Figure 2. 299HS Operational Schematic

299H Series

- Add the following table to the instruction manual.

Table 2. Type VSX-2 High and Low Trip Pressure Ranges

SETPOINT RANGES	SLAM-SHUT TYPE	FOR USE WITH MAIN VALVE SPRING NUMBER ⁽¹⁾	MINIMUM TO MAXIMUM TRIP PRESSURE	TYPE VSX-2 SPRING PART NUMBER	SPRING FREE LENGTH, INCHES (mm)	SPRING WIRE DIAMETER, INCHES (mm)
High Pressure Trip	LP	1, 2	12 to 25-inches w.c. (30 to 63 mbar)	T14162T0012	3.15 (80)	0.067 (1,7)
		1, 2, 3	20 to 52-inches w.c. (50 to 130 mbar)	T14163T0012	3.15 (80)	0.080 (2,0)
		3, 4	1.4 to 3.9 psig (95 to 270 mbar)	T14164T0012	3.15 (80)	0.091 (2,3)
		4, 5, 6	3.8 to 8.7 psig (260 to 600 mbar)	T14165T0012	3.15 (80)	0.120 (3,0)
		6, 7	5.8 to 16 psig (400 to 1100 mbar)	T14166T0012	3.15 (80)	0.138 (3,5)
		7	11.6 to 23 psig (800 to 1600 mbar)	T14167T0012	3.15 (80)	0.170 (4,3)
Low Pressure Trip	LP	2, 3	2 to 12-inches w.c. (6 to 30 mbar)	T14168T0012	3.15 (80)	0.043 (1,1)
		3, 4	4 to 30-inches w.c. (10 to 75 mbar)	T14169T0012	3.15 (80)	0.055 (1,4)
		5, 6	0.36 to 2.3 psig (25 to 160 mbar)	T14170T0012	3.15 (80)	0.067 (1,7)
		6, 7	1.5 to 10.8 psig (100 to 750 mbar)	T14171T0012	3.15 (80)	0.125 (3,2)

1. See table 1 for main valve spring number.
 Note: Other spring combinations are available, please contact your Fisher Sales Representative for additional information.

- Add the following section after the Registration Conversion section on page 5.

Type VSX-2 Installation

Note

The Type VSX-2 slam-shut module should be mounted so that the spring case vent points towards the ground.

Place new O-rings (keys 2 and 3, figure 7) on the Type VSX-2 and slide the module into the Type 299HS body (key 17, figure 7). Secure the Type VSX-2 to the Type 299HS body with the four set screws (key 4, figure 7). The Type VSX-2 device may be oriented in any direction with respect to the sensor line connection.

- Add the following sections after the Adjustment section on page 5.

Type VSX-2 Reset

Note

The over and under trip pressures can only be reset if the Type 299HS outlet pressure is between the over and under tip pressure.

Use the following procedure to reset the Type VSX-2:

1. Unscrew the brass knob to open the equalizing bypass.
2. Pull out on the knob until it stops. This resets the tripping mechanism.
3. Push in and tighten the knob.

- Add the following sections after the Adjustment section on page 5.

Type VSX-2 Trip Adjustment

Note

An adjustment tool is included with the Type VSX-2 (see figure 8). Use only this tool to make adjustments to the Type VSX-2. To make adjustments, the overpressure trip spring is found under the outer adjusting screw and the underpressure trip spring is found under the inner adjusting screw.

Use the following procedure to adjust the Overpressure Trip Spring:

1. Use the VSX adjusting tool to adjust the overpressure trip spring to its maximum compression.
2. If present adjust the underpressure spring (using the VSX adjusting tool) to its minimum compression.
3. Backpressure the unit with the desired trip pressure.
4. Reduce the overpressure trip spring compression until the Type VSX-2 trips.

Use the following procedure to adjust the Underpressure Trip Spring:

1. Use the VSX adjusting tool to adjust the underpressure trip spring to its minimum compression.
2. Backpressure the unit with the desired trip pressure.
3. Increase the underpressure trip spring compression until the Type VSX-2 trips.

- Add the following section after the Integral Pilot Control Spring and Diaphragm section beginning on page 8.

Type VSX-2 Maintenance

The Type VSX-2 device (key 1, figure 7) is designed to be removed as a unit from the Type 299HS body (key 17, figure 7) and be replaced as a complete unit. The high and low pressure springs may be adjusted or replaced without removing the slam-shut from the Type 299HS body.

299H Series

- Add the figure below.

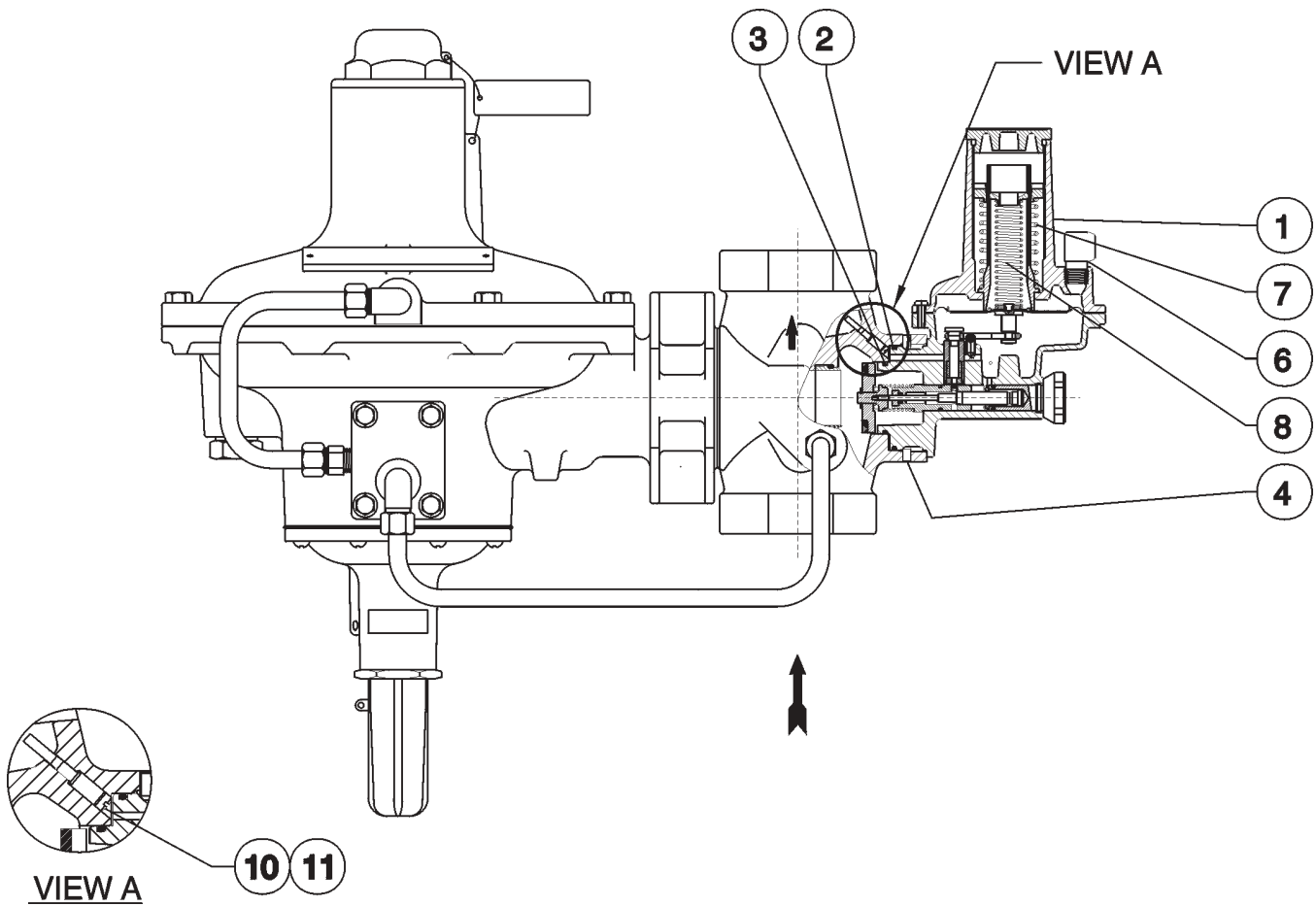

E0098

Figure 7. Type VSX-2 Assembly

- Add the figure below.



VSX ADJUSTING TOOL



VSX TOOL BEING USED TO ADJUST A TYPE VSX-2

Figure 8. VSX Adjusting Tool

- Add the following to the Parts List on page 9.

Type VSX-2 Slam-Shut Device (figure 7)

Key	Description	Part Number
1	VSX-2 Module	FA196247X12
2	Upper O-ring	T13769T0012
3	Lower O-ring	T13772T0012
4	Set Screw (4 required)	1C629828992
6	Vent Assembly	27A5516X012
7	High pressure Control Spring, zinc plated steel	
	12 to 25-inches w.c. (30 to 63 mbar), black	T14162T0012
	20 to 52-inches w.c. (50 to 130 mbar), brown	T14163T0012
	1.4 to 3.9 psi (95 to 270 mbar), red	T14164T0012
	3.8 to 8.7 psig (260 to 600 mbar), orange	T14164T0012
	5.8 to 16 psig (400 to 1100 mbar), yellow	T14166T0012
	11.6 to 23 psig (800 to 1600 mbar), green	T14167T0012
8	Low pressure Control Spring, zinc plated steel	
	2 to 12-inches w.c. (6 to 30 mbar), white	T14168T0012
	4 to 30-inches w.c. (10 to 75 mbar), blue	T14169T0012
	0.36 to 2.3 psig (25 to 160 mbar), silver	T14170T0012
	1.5 to 10.8 psig (100 to 750 mbar), olive	T14171T0012
10	Machine Screw (for external control line), steel	1H8162X0012
11	Gasket (for external control line)	T14075T0012
12	Adjustment Tool	FA142932X12
13	Pipe Plug (for internal registration)	1A767524662

299H Series

Fisher is a mark owned by Fisher Controls International, Inc., a business of Emerson Process Management. The Emerson logo is a trademark and service mark of Emerson Electric Co. All other marks are the property of their respective owners.

The contents of this publication are presented for informational purposes only, and while every effort has been made to ensure their accuracy, they are not to be construed as warranties or guarantees, express or implied, regarding the products or services described herein or their use or applicability. We reserve the right to modify or improve the designs or specifications of such products at any time without notice.

Fisher does not assume responsibility for the selection, use or maintenance of any product. Responsibility for proper selection, use and maintenance of any Fisher product remains solely with the purchaser.

For information, contact Fisher:
Marshalltown, Iowa 50158 USA
McKinney, Texas 75070 USA
28320 Gallardon, France
40013 Castel Maggiore (BO), Italy
Sao Paulo 05424 Brazil
Singapore 128461

